

**BA354D**  
**Intrinsically safe**  
**4/20mA loop-powered**  
**field mounting**  
**rate totaliser**

Issue 4

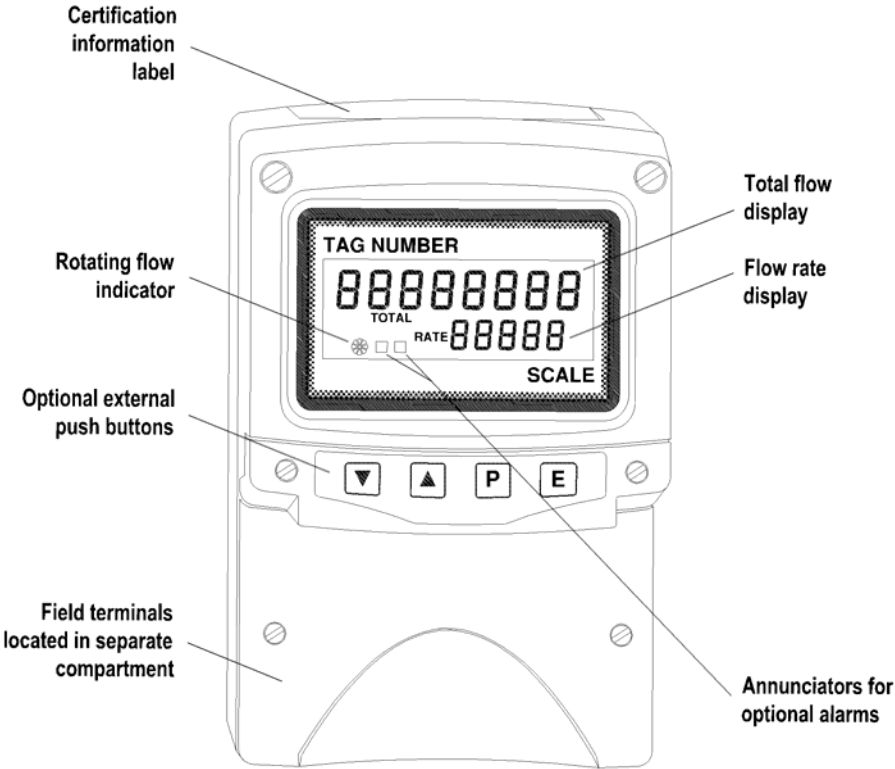

## CONTENTS

- 1. Description**
  - 2. Operation**
    - 2.1 Controls
    - 2.2 Displays
  - 3. Intrinsic Safety Certification**
    - 3.1 ATEX certificate
    - 3.2 4/20mA input
    - 3.3 Reset terminals
    - 3.4 Zones, gas groups & T rating
    - 3.5 Certification label information
  - 4. System Design for Hazardous Areas**

**ATEX certification**

    - 4.1 Flow transmitter loops
    - 4.2 Remote indication
    - 4.3 Resetting the total display to zero
  - 5. Installation**
    - 5.1 Location
    - 5.2 Installation procedure
    - 5.3 EMC
  - 6. Programming and Calibration**
    - 6.1 Calibration structure
    - 6.2 Accessing programme functions
    - 6.3 Summary of programmable functions.
    - 6.4 Root extractor
    - 6.5 Resolution
    - 6.6 Position of the decimal points
    - 6.7 Calibration of rate display using an external current source.
    - 6.8 Calibration of rate display using internal references.
    - 6.9 Conditioning sub-menu
      - 6.9.1 AC rejection
      - 6.9.2 Calibration of internal references.
    - 6.10 Resetting grand total
    - 6.11 Timebase
    - 6.12 Function of the *P* push-button
    - 6.13 Total scale factor
    - 6.14 Percentage clip-off
    - 6.15 Local reset of total display
    - 6.16 Security code
    - 6.17 Over and under-range
  - 7. Calibration Examples**
    - 7.1 Using an external current source
    - 7.2 Using the internal references
  - 8. Maintenance**
    - 8.1 Fault finding during commissioning
    - 8.2 Fault finding after commissioning
    - 8.3 Servicing
    - 8.4 Routine maintenance
    - 8.5 Guarantee
    - 8.6 Customer comments
  - 9. Accessories**
    - 9.1 Units of measurement and instrument identification.
    - 9.2 Alarms
      - 9.2.1 Solid state output
      - 9.2.2 Intrinsic safety
      - 9.2.3 Programming and adjustment
      - 9.2.4 Alarm enable
      - 9.2.5 Type of alarm
      - 9.2.6 Setpoint adjustment
      - 9.2.7 Alarm function
      - 9.2.8 Alarm output status
      - 9.2.9 Hysteresis
      - 9.2.10 Alarm delay
      - 9.2.11 Alarm silence time
      - 9.2.12 Access setpoint
      - 9.2.13 Adjusting alarm setpoints from display mode.
    - 9.3 Display backlight
    - 9.4 External push-buttons
    - 9.5 Pipe mounting kits
    - 9.6 Stem mounting kit
  - 10. Index**
- Appendix 1**  
ATEX dust certification

The BA354D is CE marked to show compliance with the  
European Explosive Atmospheres Directive 94/9/EC  
and the European EMC Directive 89/336/EEC

## 1. DESCRIPTION

The BA354D is an intrinsically safe 4/20mA loop-powered rate totaliser primarily intended for use with flowmeters. The instrument simultaneously displays the rate of flow and the total flow in engineering units on two separate displays. The BA354D only introduces a 1.1V drop which allows it to be installed into almost any 4/20mA flow loop. No additional power supply or battery is required.

The BA354D has been certified intrinsically safe by European Notified Body Intertek Testing Services (ITS) to the ATEX Directive 94/9/EC for use in explosive gas and combustible dust atmospheres. The EC-Type Examination Certificate specifies that under fault conditions the voltage, current and power at input terminals 1 and 3 will not exceed those specified for *simple apparatus* in Clause 5.4 of EN50020:1994.

ATEX dust certification is an option – See Appendix 1.

Housed in a robust IP66 glass reinforced polyester (GRP) enclosure with an armoured glass window, the BA354D is surface mounting, or may be pipe mounted using one of the accessory kits. A stem mounting kit is also available allowing direct mounting onto a flowmeter conduit entry.

## 2. OPERATION

Fig 1 shows a simplified block diagram of a BA354D. The 4/20mA input current flows through resistor R1 and forward biased diode D1. The voltage developed across D1, which is relatively constant, is multiplied by a switch mode power supply and used to power the instrument. The voltage developed across R1, which is proportional to the 4/20mA input current, provides the input signal for the analogue to digital converter.

Each time a 4/20mA current is applied to the instrument, initialisation is performed. After a short delay the following display sequence occurs:

All segments of the display are activated for about 3 seconds.

Decimal points on large display are sequentially activated for about 3 seconds.

Rate display and totaliser start to function using calibration information stored in the instrument's permanent memory.

If the 4/20mA current is disconnected during operation the latest total and grand total are stored in permanent memory.

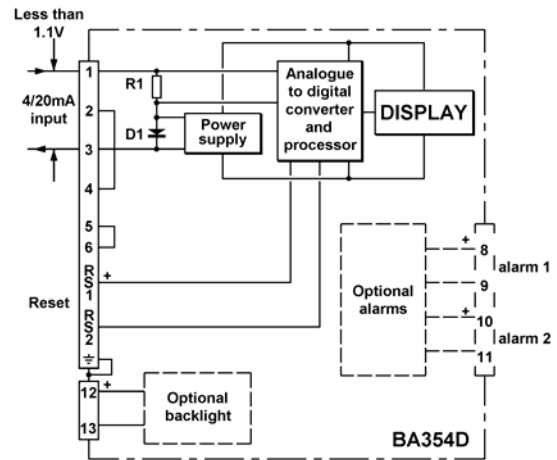

Fig 1 Simplified block diagram of BA354D

## 2.1 Controls

The BA354D is controlled and calibrated via four push-button switches which are located behind the instrument control cover, or as an option on the outside of the instrument cover. In the operating mode i.e. when the instrument is displaying rate and total flow the switch functions are:

### Summary of Switch Functions

<b>P</b>	Displays input current in mA or as a percentage of span.
<b>Down</b>	Shows rate display calibration at 4mA input
<b>Up</b>	Shows rate display calibration at 20mA input
<b>E+Down</b>	Grand total – displays least significant 8 digits
<b>E+Up</b>	Grand total – displays most significant 8 digits.
<b>Down +Up</b>	Resets total display programmable function

**Note:** When optional alarms are fitted the push-buttons may be programmed to have alternative functions – see section 9.2

## Full Description of Switch Functions

**P** While this button is pushed the rate display will show the input current in mA, or as a percentage of the instrument span depending upon how the instrument has been programmed. When the button is released the normal display in engineering units will return. The function of this push-button may be modified when alarms are fitted to the instrument.

**Down** While this button is pushed the instrument will show the calibrated rate display with 4mA input - usually zero for flow applications. When the button is released the flow rate will again be displayed.

**Up** While this button is pushed the instrument will show the calibrated rate display with 20mA input. When the button is released the flow rate will again be displayed.

**E+ Down** While these buttons are pushed the total display will show the least significant eight digits of the grand total, and the grand total annunciator will be activated.

**E+Up** While these two buttons are pushed the total display will show the most significant eight digits of the grand total and the grand total annunciator will be activated.

**Down +Up** Resets the total display to zero when these two push-buttons are operated simultaneously. Selectable function from programme menu. See section 6.15

### 2.2 Displays

The BA354D has two digital displays and associated annunciators, plus a flow indicator as shown on page 1.

**Rate Display** Shows the flow rate on the smaller five digit display.

**Total display** Shows the total flow on the larger eight digit display. Is set to zero when reset is operated.

**Flow indicator** This disc in the lower left hand corner of the display 'rotates' when the input current exceeds 4mA.

## 3. INTRINSIC SAFETY CERTIFICATION

### 3.1 ATEX certificate

The BA354D has been issued with an EC-Type Examination Certificate by Notified Body ITS Intertek Testing and Certification confirming compliance with the European ATEX Directive 94/9/EC for Group II, Category 1, gas and dust atmospheres, EEx ia IIC T5. The instrument bears the Community Mark and, subject to local codes of practice, may be installed in any of the European Economic Area (EEA) member countries. ATEX certificates are also acceptable for installations in Switzerland.

This manual describes installations in explosive gas atmospheres which conform with BS EN60079:Part14:2003 Electrical Installation in Hazardous Areas. When designing systems for installation outside the UK, the local Code of Practice should be consulted.

For the use in the presence of combustible dust, please refer to Appendix 1 which describes installations complying with BS EN 50281-1-2:1999. Please note that dust certification is an option which must be specified when the instrument is ordered.

### 3.2 4/20mA input

In Europe, sources of energy which do not generate more than 1.5V; 100mA and 25mW are, for intrinsic safety purposes, considered to be *simple apparatus* (Clause 5.4 of EN50 020:1994).

Although the BA354D indicator does not itself comply with the requirements for *simple apparatus*, the EC-Type Examination Certificate specifies that under fault conditions the voltage, current and power at the 4/20mA input terminals 1 and 3 will not exceed those specified for *simple apparatus* in Clause 5.4 of EN50020:1994. This allows the BA354D 4/20mA input terminals to be connected into any intrinsically safe circuit protected by a Zener barrier or galvanic isolator without the need for additional certification, providing the output parameters of the circuit do not exceed:

Uo	30V dc
Io	200mA dc
Po	0.85W

The BA354D EC-Type Examination Certificate specifies that the maximum equivalent capacitance and inductance between the two 4/20mA input terminals 1 and 3 is:

Ci	20nF
Li	10 H

To determine the maximum permissible cable parameters these figures must be subtracted from the maximum cable capacitance and inductance permitted by the system certificate of the loop into which the BA354D is connected.

### 3.3 Reset terminals

The BA354D total display may be reset to zero by connecting the reset terminals RS1 and RS2 together. These two terminals have the following output and input safety parameters:

Uo	5V dc
Io	1.3mA dc
Po	1.6mW

Ui	28V dc
Ii	98mA dc
Pi	0.65W

The maximum equivalent capacitance and inductance between them is:

Ci	1.2nF
Li	0 H

The total display may be reset to zero from within the hazardous area by any mechanically operated switch connected directly to terminals RS1 and RS2. Alternatively, the BA354D may be programmed so that the total display is reset to zero when the *Up* and *Down* push-buttons are operated simultaneously.

To reset the total display from the safe area a Zener barrier or intrinsically safe relay is required to transfer the contact closure into the hazardous area. The BA354D system certificates define suitable interface devices together with the maximum permissible cable parameters. Almost any intrinsically safe relay with certification permitting the contacts to be connected to equipment in the hazardous area may be used. Alternatively, one of the positive diode return Zener barriers listed in the system certificate may be used - see Fig 3A.

### 3.4 Zones, gas groups and T rating

The BA354D has been issued with an EC Type Examination certificate confirming that it complies with the requirements for Group II Category 1 G EEx ia IIC T5 (Tamb -40 to 60°C) specified in the ATEX Directive. When connected to a suitable system the BA354D may be installed in:

Zone 0	explosive gas air mixture continuously present.
Zone 1	explosive gas air mixture Likely to occur in normal operation.
Zone 2	explosive gas air mixture not likely to occur, and if it does will only exist for a short time.

Be used with gases in groups:

Group A	propane
Group B	ethylene
Group C	hydrogen

Having a temperature classification of:

T1	450°C
T2	300°C
T3	200°C
T4	135°C
T5	100°C

At an ambient temperature between -40 and +60°C.

**Note:** the guaranteed operating temperature range is -20 to +60°C

This allows the BA354D to be installed in all Zones and to be used with most common industrial gases.

### 3.5 Certification Label Information

The certification label is fitted in a recess on the top outer surface of the enclosure. It shows the ATEX certification information plus BEKA associates' name and location. Non European certification information may also be included. The instrument serial number and date of manufacture are recorded on a separate label inside the terminal compartment.

BA354D Loop Powered Rate Totaliser	
 	0359 II 1 G Tamb = -40°C to +60°C
EEx ia IIC T5 ITS00ATEX2009	
Year of manufacture shown within terminal compartment	
BEKA associates Ltd Hitchin England <a href="http://www.beka.co.uk">www.beka.co.uk</a>	

## 4. SYSTEM DESIGN FOR HAZARDOUS AREA

### 4.1 Flow transmitter loops

A BA354D rate totaliser may be connected in series with almost any intrinsically safe 4/20mA flow loop and calibrated to display the rate of flow and total flow. There are two basic design requirements:

1. The intrinsic safety output parameters of the 4/20mA loop, which are defined by the Zener barrier or galvanic isolator, must be less than:

$U_o$	30V dc
$I_o$	200mA dc
$P_o$	0.85W

2. The loop must be able to tolerate the additional 1.1V required to operate the indicator.

Fig 2 illustrates an application in which a BA354D indicator is connected in series with a 2-wire flow transmitter protected by a Zener barrier.

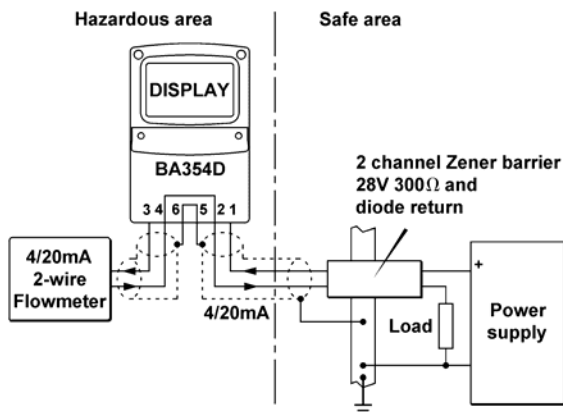

Fig 2 BA354D in a flow loop

### 4.2 Remote indication

A BA354D may be driven via an intrinsically safe interface from a 4/20mA safe area signal to provide a remote indication of rate and total flow within a hazardous area. The type of interface is not critical, either a Zener barrier or a galvanic isolator may be used, providing that  $U_o$ ,  $I_o$  and  $P_o$  are not exceeded.

If one side of the 4/20mA current loop may be earthed, a single channel Zener barrier provides the lowest cost protection. If the 4/20mA signal is not isolated, then two Zener barriers, a two channel Zener barrier or a galvanic isolator must be used.

When the hazard is a IIC gas, and two single channel Zener barriers or a two channel Zener barrier are used, only one barrier or channel may be a 28V 300ohm device. A 10V 50 or diode return barrier may be used for the second channel to form a safe combination.

Again it is necessary to ensure that the voltage capability of the 4/20mA signal is sufficient to drive the indicator plus the voltage drop introduced by the intrinsically safe interface. Figs 3A, 3B and 3C show the alternative circuits which may be used.

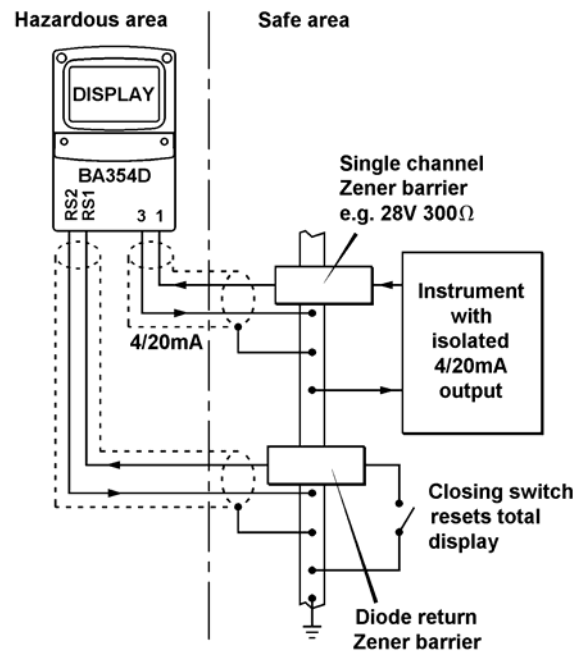

Fig 3A Simplest circuit with one side of 20mA current loop connected to earth. Also shows optional resetting from safe area.

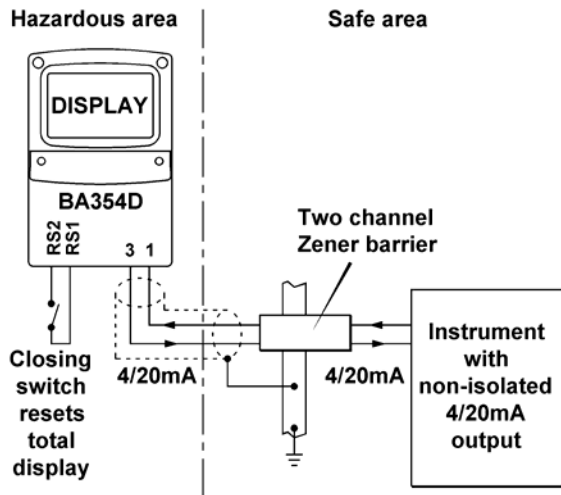

Fig 3B Two Zener barrier channels are required if the 4/20mA current loop can't be earthed at the barrier busbar.  
Also shows optional resetting from hazardous area

### 4.3 Resetting the total display to zero

The BA354D may be programmed to reset the total display to zero when the *Up* and *Down* buttons are pushed simultaneously for 2 seconds, or an external switch located in the safe or the hazardous area may be used. Fig 3A illustrates how the total display may be reset from the safe area via a single channel diode return Zener barrier. A certified intrinsically safe relay or certified opto-isolator may also be used.

Fig 3B shows how the total display may be reset to zero by an external switch in the hazardous area. The switch must be mechanically operated and able to withstand a 500V dc insulation test, but no Zener barrier or galvanic isolator is required.

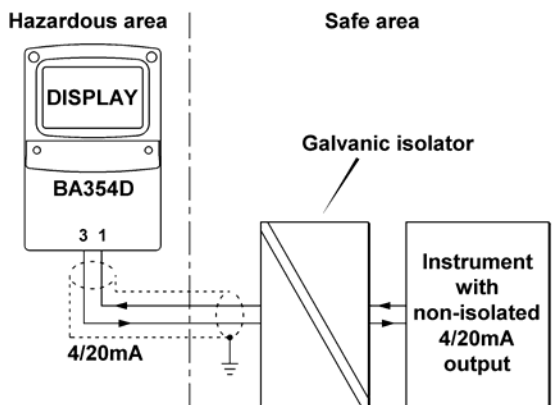

Fig 3C Galvanic isolator can be used with any 4/20mA current loop.

## 5. INSTALLATION

### 5.1 Location

The BA354D rate totaliser is housed in a robust IP66 glass reinforced polyester (GRP) enclosure incorporating an armoured glass window and stainless steel fittings. It is suitable for exterior mounting in most industrial environments, including off-shore and waste water treatment. Please consult BEKA associates if high vibration is anticipated.

The BA354D enclosure is surface mounting. Accessory kits described in sections 9.5 & 9.6 of this manual enable the instrument to be mounted onto a vertical or horizontal pipe, or directly onto a flowmeter conduit entry.

The field terminals and the two mounting holes are located in a separate compartment with a sealed cover allowing the instrument to be installed without exposing the display assembly.

Terminals 2 and 4 are internally joined and may be used for linking the return 4/20mA wire - see Fig 2. Similarly terminals 5 and 6 are internally joined and may be used for linking the cable screens. The BA354D earth terminal is connected to the internal EMC filters. For maximum radio frequency interference rejection this terminal should be connected to a local earth, or to a cable screen which is earthed in the safe area. To prevent circulating currents, cable screens should only be earthed at one point in the safe area.

The BA354D enclosure is supplied with a bonding plate to ensure electrical continuity between the three conduit / cable entries.

### 5.2 Installation Procedure

Fig 4 illustrates the instrument installation procedure.

- Remove the instrument terminal cover by unscrewing the two captive 'A' screws.
- Mount the instrument on a flat surface and secure with two M6 screws through the 'B' holes. Alternatively use one of the mounting kits described in section 9.5
- Remove the temporary dust seals from the three cable entries and install the required glands, conduit fittings or blanking plugs.

Note: the temporary dust seals do not provide IP66 protection.

- Connect the field wiring to the terminals as shown in Fig 5.
- Replace the instrument terminal cover and evenly tighten the two 'A' screws.

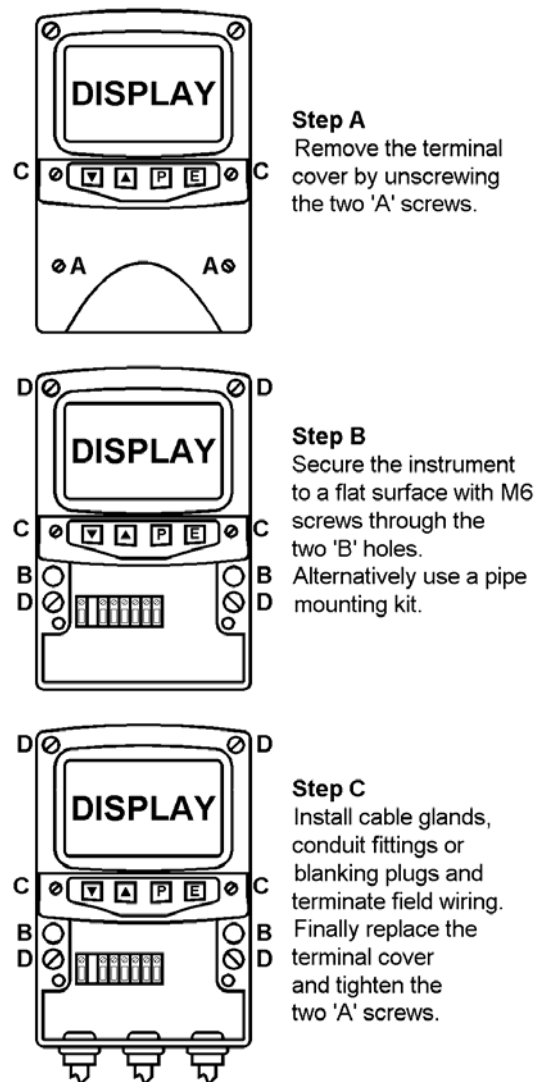

Fig 4 BA354D installation procedure

### 5.3 EMC

The BA354D complies with the requirements of the European EMC Directive 89/336/EEC. For specified immunity all wiring should be in screened twisted pairs, with the screens earthed in the safe area.

Additional immunity may be obtained by connecting the BA354D earth terminal to a local earth, or to a cable screen which is earthed in the safe area. If this terminal is not connected, personal and intrinsic safety will not be degraded.

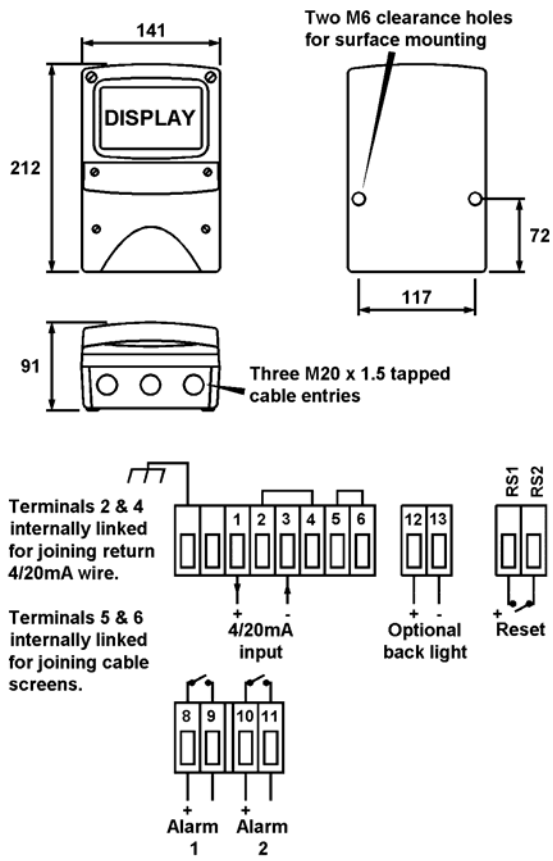

Fig 5 Dimensions and terminal connections

## 6. PROGRAMMING & CALIBRATION

The BA354D is programmed and calibrated via four push-buttons which are located behind the instrument control cover. If frequent access to the push-buttons is required, the rate totaliser can be supplied with duplicate membrane push-buttons mounted on the outside of the control cover.

All the programming functions are contained in an easy to use menu which is shown diagrammatically in Figs 7A and 7B. Each function is summarised in section 6.3 which includes references to more detailed information. Although this simple menu driven system enables most adjustments to be made without repeated reference to this manual, it is recommended that at least the summary of the programmable functions in section 6.3 is read before attempting programming or recalibration.

When the instrument is fitted with alarms, the basic menu is expanded to include the alarm functions that are described in section 9.2 of this manual.

**Note:** While the instrument is being programmed or calibrated totalisation is suspended, any flow occurring during this time will not be recorded.

### 6.1 Calibration structure

Fig 6 shows the BA354D calibration structure. The 4/20mA input current, which in flow applications represents flow rate, is displayed on the five digit rate display. Using the instrument 'CAL' or 'SEt' functions this display may be calibrated to show the flow rate in engineering units. Both the zero (display at 4mA) and the span (display at 20mA) are adjustable, although for flow application the display at 4mA is usually zero. The position of the decimal point in the rate display is defined by the d.p. function. To simplify calibration the BA354D uses floating point arithmetic, moving the rate display decimal point position will therefore affect totalisation.

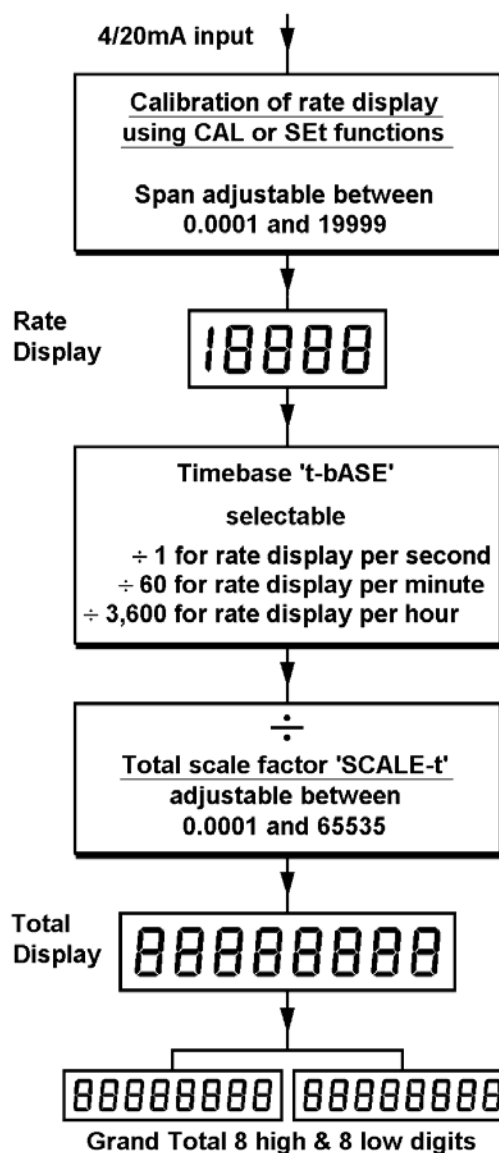

Fig 6 Calibration structure

The BA354D total display is calculated from the rate display using two serial factors: the timebase 't-bASE' and the total scaling factor 'SCALE-t'. The timebase divides the rate display according to whether the rate display represents flow per second, per minute or per hour. The total scaling factor 'SCALE-t' is a wide range programmable dividing factor allowing the rate and total displays to be in different units.

For example, if a BA354D is displaying rate in litres per minute, setting 'SCALE-t' to 4.5461 produces a total display in UK gallons. Alternatively, setting 'SCALE-t' to 4546.1 will produce a total display in thousands of UK gallons.

The total is calculated and the display updated twice per second, which defines the resolution of the total flow display. When total alarms are used for batching applications, this resolution may define the accuracy of the system.

## 6.2 Accessing programming functions

Throughout this manual push-buttons are shown in italics e.g. *P* or *Up* push-button, and legends displayed by the instrument are shown within inverted commas e.g. 'CAL' and 'ALr2'.

Access to the programme menu is obtained by operating the *P* and *E* push-buttons simultaneously. If the instrument is not protected by a security code the first parameter 'root' will be displayed. If a security code other than the default code 0000 has already been entered, the instrument will display 'COdE'. Press *P* to clear this prompt and enter the security code for the instrument using the *Up* or *Down* push-button adjust each digit, and the *P* push-button to move control to the next digit. If the correct code has been entered pressing *E* will cause the first parameter 'root' to be displayed. If an incorrect code is entered, or a push-button is not operated, the instrument will timeout after ten seconds and automatically return to the display mode.

Apart from defining the position of the decimal point in the rate display all programme functions and prompts are shown on the large eight digit display.

Once within the main programme menu the required parameter can be reached by scrolling through the menu using the *Up* and *Down* push-buttons as shown by the programme structure in Figs 7A and 7B. When returning to the operating mode following recalibration or changes to any parameters, the total display will show circulating decimal points for a few seconds while the new information is stored in permanent memory.

All new BA354D are supplied calibrated as requested at the time of ordering. If calibration information is not supplied, the BA354D will be set to display a rate of 0.00 with 4mA input and 100.00 with 20mA input. The total scale factor will be set to 1 with a timebase of seconds.

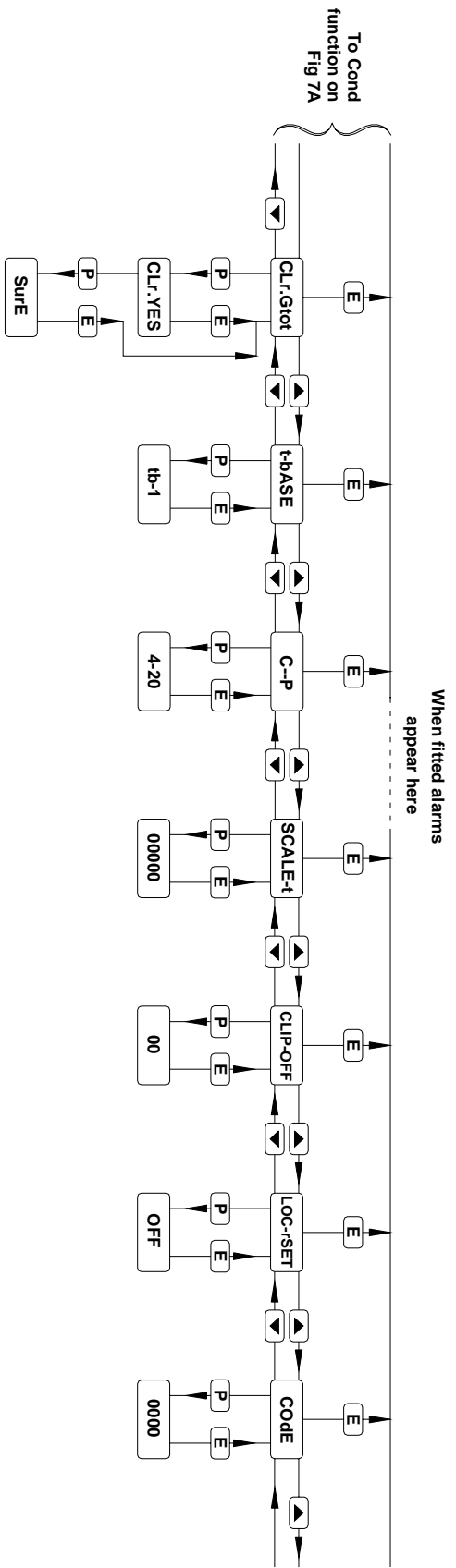

**Clear grand total**

Enter by pressing **CLR:Gtot** and **Sure**

**Timebase**

Enter by pressing **tBASE** and **tB-1**

**Function of P button**

Enter by pressing **C-P** and **4-20**

**Total scale factor**

Enter by pressing **SCALE-1** and **00000**

**% clip-off**

Enter by pressing **CLIP-OFF** and **00**

**Local reset**

Enter by pressing **LOC-SET** and **OFF**

**Define Security Code**

Enter by pressing **CODE** and **0000**

**Clear grand total**

Enter by pressing **CLR:Gtot** and **Sure**

**Timebase**

Enter by pressing **tBASE** and **tB-1**

**Function of P button**

Enter by pressing **C-P** and **4-20**

**Total scale factor**

Enter by pressing **SCALE-1** and **00000**

**% clip-off**

Enter by pressing **CLIP-OFF** and **00**

**Local reset**

Enter by pressing **LOC-SET** and **OFF**

**Define Security Code**

Enter by pressing **CODE** and **0000**

**WARNING**

Cleared grand total can not be recovered

Fig 7B. Programme Structure

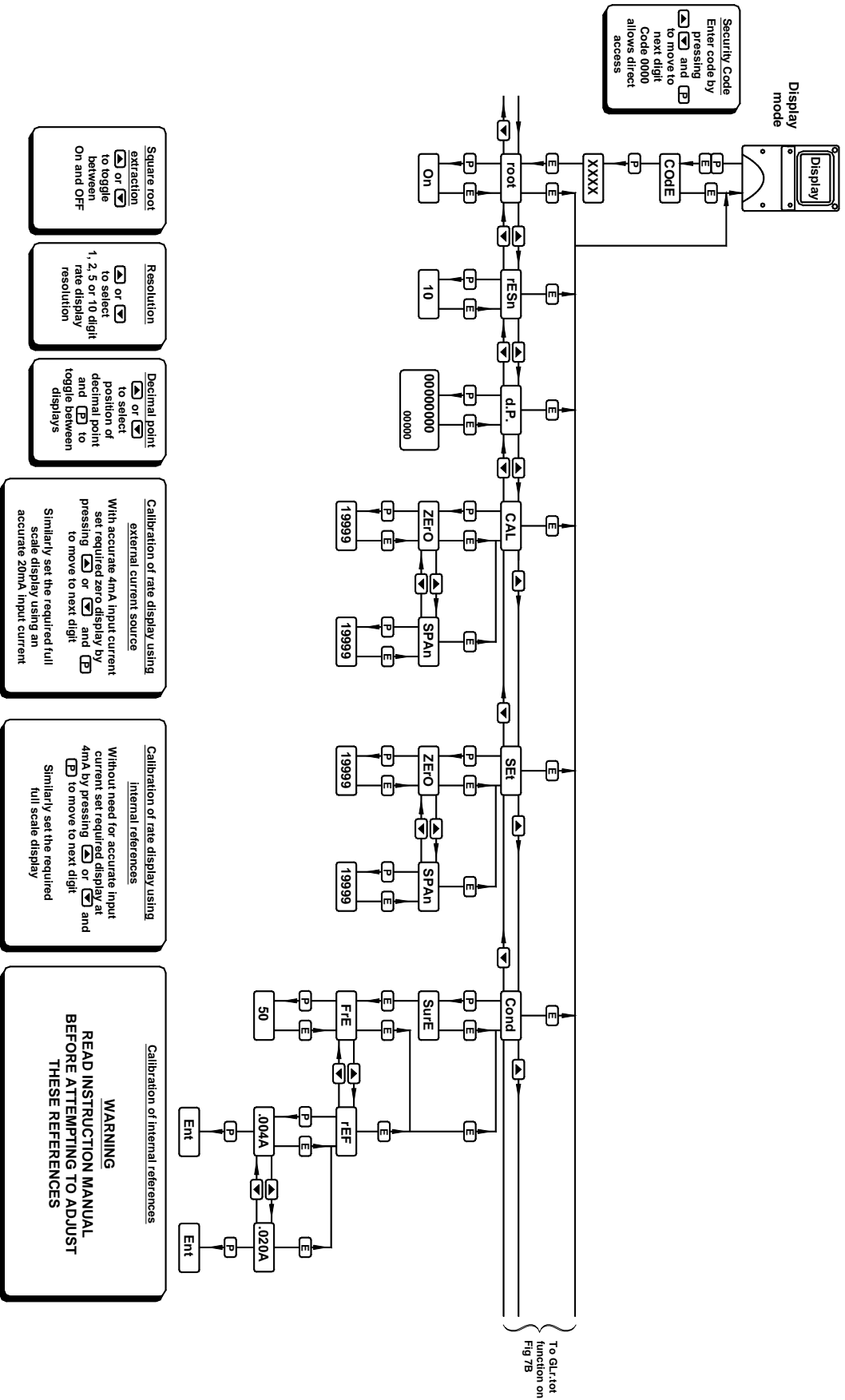

Fig 7A. Programme Structure

### 6.3 Summary of programmable functions

This section summarises all of the programmable functions. When read with Figs 7A and 7B it provides a quick aid for calibrating the instrument. If more detail is required, each section contains a reference to a full description of the function.

#### SUMMARY

<u>Display</u>	<u>Description of function</u>
'root'	<p><b>Square root extractor</b> Enables the square root extractor for linearising the output from differential flowmeters. Percentage clip-off, below which the instrument does not totalise, is automatically set to 5% of maximum flow when the 'root' function is turned 'On'. See section 6.4</p>
'rESn'	<p><b>Display resolution</b> Selects the resolution of the least significant digit of the rate display. May be set to 1, 2, 5 or 10 digits. See section 6.5</p>
'd.P.'	<p><b>Decimal points</b> Defines the position of the decimal point in both the rate and total displays. See section 6.6</p>
'CAL'	<p><b>Calibration of rate display using external current source.</b> Enables the zero and span of the rate display to be adjusted using an external current source such as a calibrator. Also enables a complete loop to be calibrated from primary element to the indicator display. When used with an accurate traceable current source this is the preferred method of calibration. See section 6.7</p>
'SEt'	<p><b>Calibration of rate display using internal references.</b> Enables the zero and span of the rate display to be adjusted without the need for an accurate input current or disconnection from the 4/20mA loop. See section 6.8</p>

#### Display      Description of function

'Cond'	<p><b>Indicator conditioning</b> This is a protected sub-menu which contains the calibration routine for the two internal references 'rEF', and the mains (line) frequency selection function 'FrE'. See section 6.9</p>
--------	--

#### CAUTION

**Please read sections 6.9 and 6.9.1 of this manual before changing any of the parameters in this sub-menu. Incorrect adjustment may result in reading errors.**

'CLr. Gtot'	<p><b>Clears grand total</b> This function resets the grand total to zero when 'CLr YES' is selected, and 'SurE' is entered to confirm the instruction. Note: Once cleared, a grand total can not be recovered. See section 6.10</p>
-------------	--

't-bASE'	<p><b>Timebase</b> Three selectable divisors which define whether the rate display represents flow per second, per minute or per hour. See section 6.11 &amp; Fig 6.</p>
----------	--

'C - - P'	<p><b>Function of P push-button in display mode</b> The instrument may be programmed to show on the rate display the input current in milliamps, or the input as a percentage when the P push-button is operated in the display mode. Select 'PC' to display % of span and '4-20' to display the input current. See section 6.12</p>
-----------	--

<u>Display</u>	<u>Description of function</u>
<b>'SCALE-t'</b>	<p><b>Total Scale Factor</b> Defines the arithmetic relationship between the rate and total displays. May be adjusted between 0.0001 and 65535</p> <p><math display="block">\text{SCALE-t} = \frac{\text{Units of rate display}}{\text{Units of total display}}</math></p> <p>To calculate SCALE-t the required units of measurement for the total display must be converted to the units of measurement used for the rate display. See section 6.13, 7 and Fig 6.</p>
<b>'CLIP-OFF'</b>	<p><b>Percentage Clip off</b> To prevent the totalisation of very low flow rates, this function enables the user to select a percentage rate below which the rate display is forced to zero. Adjustable between 0 and 10% of flow for linear inputs, and 5 to 10% when the root function is used to linearise a square law input. See section 6.14</p>
<b>'LOC.rSEt'</b>	<p><b>Local reset of total display</b> When turned 'On' this function enables the total display to be reset to zero by simultaneously operating the <i>Up</i> and <i>Down</i> push-buttons. See section 6.15</p>
<b>'COdE'</b>	<p><b>Security code</b> Defines a four digit numeric code which must be entered to gain access to programmable functions. Default code 0000 disables the security function and allows unrestricted access to all programmable functions. See section 6.16</p>

#### 6.4 Root extractor: root

This function is primarily intended for use with differential flowmeters which have a square law 4/20mA output. The root extractor linearises the flow signal and enables the BA354D to display rate and total in linear units.

To activate the square root extractor select 'root' from the menu and press *P* which will reveal if the function is 'On' or 'OFF'. If the function is set as required, press *E* to return to the menu, or press the *Up* or *Down* button to change the setting, followed by the *E* button to return to the main menu.

For reference, the following table shows the output current from a non-linearised differential flowmeter.

% of full flow	Current output mA
2.5	4.01
10.0	4.16
25.0	5.00
50.0	8.00
75.0	13.00
100.0	20.00

#### 6.5 Resolution: rESn

This function defines the resolution of the least significant rate display digit. Decreasing the display resolution can improve the readability of a noisy signal. Select 'rESn' from the menu and press *P* which will reveal the current display resolution. To change the resolution press the *Up* or *Down* button to select 1, 2, 5 or 10 digits, followed by the *E* button to return to the menu.

#### 6.6 Position of the decimal points: d.P.

This function positions the decimal point in both the rate and total displays.

The rate display can have up to five digits and the decimal point may be positioned between any of them, or omitted. The BA354D uses *floating point arithmetic* so moving the position of the rate display decimal point will affect totalisation. Similarly the total display has eight digits and the decimal point may be positioned between any of them, or may be omitted.

To adjust the position of either decimal point select 'd.P.' from the main menu and press *P*. This will activate both displays with one digit plus the following decimal point of the total display flashing. If only the least significant digit is flashing, this indicates that the decimal point is omitted.

The position of the decimal point can be moved by pressing the *Up* or *Down* push-button. Operating the *P* push-button will toggle control

between the two displays. When both decimal points have been correctly positioned press *E* to return to the main menu.

If the application requires flow rate to be the primary display i.e. shown on the large display, the d.P. function enables the rate and total displays to be interchanged. The rate display will continue to have five digits but the total display will be reduced from eight to six digits. The rate and total annunciators will also be interchanged. Pressing the *Up* and *Down* buttons simultaneously will interchange the displays.

### 6.7 Calibration of the rate display using an external current source: CAL

This function enables the zero and span of the rate display to be adjusted using an external current source such as a 4/20mA calibrator. When used with an accurate traceable current source this is the preferred method of calibration.

To calibrate the instrument, select 'CAL' from the main menu and press *P*. The indicator will display 'ZEro' which is a request for a 4mA input current. Adjust the external current calibrator to 4.000mA and again press *P* which will reveal the existing zero rate display. For flow applications this will usually be zero. Each digit of the rate display can be changed by pressing the *Up* or *Down* buttons. When the first digit is correct pressing *P* will transfer control to the next digit. The most significant digit, which can be 1 or 2 is set by rolling over the previous digit. When all the digits have been adjusted, press *E* to enter the new zero. The indicator will display 'Ent' for a few seconds while the information is being stored in memory, and will then return to the 'ZEro' prompt.

To adjust the rate display at 20mA, press the *Up* button which will cause the instrument to display 'SPAN'. Adjust the external current calibrator to 20.000mA and again press *P* which will reveal the existing full scale display. Each digit of the rate display can be changed by pressing the *Up* or *Down* buttons. When the first digit is correct pressing *P* will transfer control to the next digit. The most significant digit, which can be 1 or 2 is set by rolling over the previous digit. When all the digits have been adjusted press *E* to enter the new span. The instrument will display 'Ent' for a few seconds while the information is being stored in memory, and will then return to the 'SPAN' prompt. Finally press *E* again to return to the main menu.

This function may also be used to calibrate a complete loop including the flow meter.

### 6.8 Calibration of rate display using internal references: SEt

This function enables the zero and span of the rate display to be adjusted without the need for an accurate external current source, or for disconnection from the 4/20mA loop. The accuracy of this method depends upon the accuracy of the internal references which should be regularly calibrated as described in section 6.9.2

To calibrate the rate display select 'SEt' from the main menu and press *P*. The instrument will display 'ZEro', pressing *P* again will reveal the current display at 4mA. For flow applications this will usually be zero. Each digit of the rate display can be changed by pressing the *Up* or *Down* buttons. When the first digit is correct pressing *P* will transfer control to the next digit. When the least significant digit has been adjusted, press *E* to return to the 'ZEro' prompt which completes the adjustment.

To adjust the rate display at 20mA, press the *Up* button which will cause the instrument to display 'SPAN'. Pressing *P* again will reveal the indicator display. Each digit can be changed by pressing the *Up* or *Down* buttons. When the first digit is correct, pressing *P* will transfer control to the next digit. The most significant digit, which can be 1 or 2, is set by rolling over the previous digit. When all the digits have been adjusted press *E* to return to the 'SPAN' prompt, followed by *E* to return to the main menu.

### 6.9 Conditioning sub-menu: Cond

This sub-menu allows the mains (line) frequency at which the instrument has maximum ac rejection to be selected and the two internal references to be calibrated. These functions are contained in a protected sub-menu to minimise the possibility of accidental adjustment. To gain access to the sub-menu select 'Cond' from the main menu and press *P* which will cause the instrument to display '0000'. Using the *Up*, and *Down* buttons and the *P* button to move to the next digit enter the password 'SurE'. Pressing *E* will then give access to the sub-menu. Note 'S' is entered as '5'.

### 6.9.1 AC rejection: FrE

#### WARNING

**If the mains filter frequency is changed, the rate display and the internal references (if used) must be recalibrated.**

To provide maximum low frequency rejection the internal digital filter may be set to operate at 50 or 60Hz to correspond with the local mains (line) frequency. To change the frequency select 'FrE' from the 'Cond' sub-menu and press *P* which will reveal the current setting. The setting can be changed by pressing the *Up* or *Down* buttons followed by the *E* button to return to the sub-menu.

### 6.9.2 Calibration of internal references: rEF

The BA354D contains two references representing 4 and 20mA. These are used in the 'SEt' function which enables the rate display to be calibrated without an external current calibrator. They are also used in the 'C--P' function when the *P* push-button is programmed to display the input current in the operating mode. If either of these two functions are used, the internal references should be routinely calibrated against an external 4/20mA calibrator connected to the input terminals of the instrument. See section 8.4

To calibrate the internal references select 'rEF' from the sub-menu and press *P* which will result in a '.004A' prompt being displayed. Adjust the external current calibrator to 4.000mA and again press *P*. The instrument will display 'Ent' while the 4mA reference is being updated and will then return to the '.004A' prompt.

To re-calibrate the 20mA internal reference, press the *Up* button which will cause the instrument to display '.020A'. Adjust the external current calibrator to 20.000mA and again press *P*. The instrument will display 'Ent' while the 20mA reference is being updated and will then return to the '.020A' prompt. This completes calibration of the internal references, two operations of the *E* button will return the instrument to the 'Cond' prompt in the main menu.

### 6.10 Resetting grand total: CLr. Gtot

The grand total is a separate sixteen digit counter which duplicates the total display but is not zeroed when the total display is reset to zero. The grand total may be viewed in the

operating mode in two eight digit sections as described in section 2.1 of this manual.

The grand total counter can only be reset to zero from the 'CLr. Gtot' function in the main programme menu. To zero the grand total counter select 'CLr. Gtot' and press *P* which will cause the instrument to display 'Clr. no' with 'no' flashing. Continuously press the *Up* or *Down* push-buttons until 'CLr. YES' is displayed and then press *P* which will result in a '0000' prompt. Using the *Up*, and *Down* buttons and the *P* button to move to the next digit, confirm the request by entering the password 'SurE'. Note 'S' is entered as '5'. Pressing *E* will then reset the grand total counter to zero and return the instrument to the 'CLr. Gtot' prompt in the main menu.

#### WARNING

**After resetting the grand total counter to zero the old grand total can not be recovered.**

### 6.11 Timebase: t-bASE

Together with the total scale factor 'SCALE-t', this function defines the arithmetic relationship between the rate and total displays. The timebase divides the rate display by 1, 60 or 3,600 depending upon whether the BA354D rate display represents flow per second, per minute or per hour. See Fig 6.

To check or change the timebase select 't-bASE' from the main menu and press *P* which will reveal the current setting. Pressing the *Up* or *Down* button will index through the following three options.

BA354D Rate display Represents Flow	Select In t-bASE menu	Total display = rate display divided by
Per second	tb – 1	1
Per minute	tb – 60	60
Per hour	Tb – 3600	3600

Select the required divisor and press *E* to return to the main menu.

### 6.12 Function of the *P* push-button: C - - P

This parameter defines the function of the *P* push-button when the BA354D is in the operating mode. Either the input current in milliamps or the input as a percentage of the span may be shown.

To check or change the parameter select 'C - - P' from the main menu and press *P* to reveal the current setting. Pressing the *Up* or *Down* button will toggle the instrument between the two options; '4-20' and 'PC', the input current in milliamps and the input as a percentage of span. When the required option is displayed press *E* to store the selection and return to the main menu.

Accuracy of both these options depends upon the accuracy of the internal references which should be periodically calibrated - see section 6.9.2

### 6.13 Total scale factor: SCALE-t

Together with the timebase 't-BASE', this is a dividing factor which defines the arithmetic relationship between the rate and total displays. The total scale factor may be set to any value between 0.0001 and 65535\* allowing the total flow and rate of flow to be displayed in different engineering units.

$$\text{SCALE-t} = \frac{\text{Units of rate display}}{\text{Units of total display}}$$

When calculating SCALE-t the required units of measurement for the total display must be converted to those used for the rate display as shown in following example:

The BA354D rate display represents litres per second but the total flow display is required in UK gallons. There are 4.5461 litres in a UK gallon.

$$\begin{aligned} \text{SCALE-t} &= \frac{\text{Units of rate display}}{\text{Units of total display}} \\ &= \frac{1 \text{ litre}}{1 \text{ gallon}} = \frac{1 \text{ litre}}{1/(4.5461) \text{ litres}} \end{aligned}$$

$$\text{SCALE-t} = 4.5461$$

Alternatively if the total display is required in thousand of UK gallons

$$= \frac{1 \text{ litre}}{1 \text{ gallon}} = \frac{1 \text{ litre}}{1/(4546.1) \text{ litres}}$$

$$\text{SCALE-t} = 4546.1$$

The total scale factor SCALE-t is not dependent on the rate display units of time. i.e. flow units per second, minute or per hour. The timebase t-BASE accounts for these differences.

To check or change the total scale factor select 'SCALE-t' from the main menu and press *P* to reveal the existing setting, one digit will be flashing. The value of the flashing digit can be changed by pressing the *Up* or *Down* buttons. When this digit is correct pressing *P* will transfer control to the next digit.

To position the decimal point, move the flashing digit to the left hand side of the required decimal point position and simultaneously press the *Up* and *Down* buttons.

When the required total scale factor has been entered, press *E* to store the number and return to the main menu.

**\*Note:** The maximum numerical value of SCALE-t is 65535 irrespective of the decimal point position. i.e. 6.5535; 65.535; 655.35; 6553.5 and 65535.

### 6.14 Percentage Clip-off: CLIP-OFF

To prevent totalisation of very low flow rates which over long periods may result in significant totalisation errors, the BA354D rate display can be forced to zero when the flow rate falls below a specified value. The threshold may be adjusted between 0 and 10% of flow for linear inputs, and between 5 and 10% of flow for square law inputs linearised by the root extractor.

To check or change the clip-off threshold select 'CLIP-OFF' from the main menu and press *P* to reveal the current setting. The threshold, which is shown as a percentage of total flow, may be adjusted in one percent increments using the *Up* or *Down* buttons. When set as required, press the *E* button to enter the revised figure and return to the main programme menu.

### 6.15 Local reset of total display: LOC. rSET

This function enables the operator to reset the BA354D total display to zero by operating the *Up* and *Down* push-buttons simultaneously. To check the status of the local reset function select 'LOC. rSET' from the menu and press *P* which will reveal if the function is 'On' or 'OFF'. If necessary press the *Up* or *Down* button to change the setting, followed by the *E* button to return to the main menu.

### 6.16 Security code: COdE

The calibration and conditioning of the instrument may be protected by a four digit security code which must be entered before access to the programme menu is granted. New instruments are programmed with the default security code 0000 which allows unrestricted access to all programming functions.

To enter a new security code select 'COdE' from the menu and press *P* which will cause the instrument to display the current security code. Each digit of the code can be changed using the *Up* and *Down* push-buttons, and the *P* button to move to the next digit. When the required code has been entered press *E* to return to the main menu. The revised security code will be activated when the indicator is returned to the operating mode.

If the security code is lost, access to the programmable functions can be obtained by moving the internal security link to the override position. The original security code can then be viewed by selecting 'CodE' from the main menu and pressing *P*.

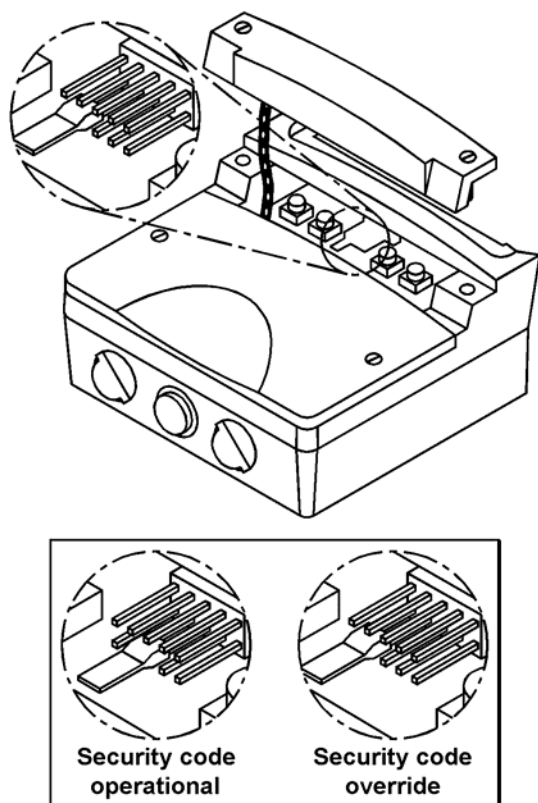

Fig 8 Location of security code override link

To gain access to the security code link, remove the instrument control cover by undoing the two 'C' screws - see Fig 4. If the

instrument is fitted with external push-buttons the connecting ribbon cable should be unplugged. The security code override link is located on the inner row of the five pin connector shown in Fig 8.

### 6.17 Over and under-range

If the rate display range is exceeded, the four least significant digits will be blanked. Under-range is indicated by a flashing '-1' and over-range by '1'. Under and over-range are also indicated if the input current falls below approximately 3.6mA or rises above approximately 21mA.

If the input current falls below approximately 3mA the instrument initialisation sequence is performed as described in section 2.

When the total display exceeds 99999999 it will automatically roll-over to zero and continue counting. If this is likely to happen the grand total should be reset at the start of the operation, the most significant eight digits of the grand total will then indicate how many times the total display has rolled-over. The most significant eight digits of the grand total can be viewed by pressing the *E* and *Up* buttons simultaneously. Up to  $10^8$  roll-overs can be counted.

## 7. CALIBRATION EXAMPLES

This section includes two examples illustrating how a BA354D rate totaliser may be programmed and calibrated to display the rate of flow and total flow measured by a flow meter with a 4/20mA output. Section 7.1 describes the preferred method of calibration using an external traceable 4/20mA calibrator. Section 7.2 contains an example of calibration using the BA354D internal 4 and 20mA references, which although not traceable, are adequate for many industrial applications.

### 7.1 Using an external current source

In this example the BA354D rate totaliser is connected to a flowmeter having an output of 20mA at a flow of 1100 litres / minute. The BA354D is required to display flow in litres per minute and total flow in cubic metres with a resolution of 0.1 cubic metres. Totalisation is to occur for flow rates between 1 and 100% of maximum flow. The frequency of the mains supply is 50Hz and a security code of 1209 is required. In the operating mode the BA354D is required to display the input current as a percentage of span when the *P* push-button is operated.

#### Step 1 Connect instrument to calibrator

Connect the BA354D to an accurate current source such as a calibrator. Terminal 1 positive and terminal 3 negative. The instrument will perform the initialisation routine described in section 2, and then display the input current on the rate display using the existing calibration information.

#### Step 2 Enter the programming mode

With an input current between 4 and 20mA put the instrument in the programming mode by simultaneously pressing *P* and *E*. Assuming a security code has not already been entered the instrument will respond by displaying 'root' which is the first function in the main menu. See Figs 7a and 7b.

#### Step 3 Turn square root extractor off

With 'root' displayed, press *P* which will reveal the root extractor status. The root extractor can be turned on or off by operating the *Up* or *Down* buttons. Select 'OFF', and press *E* to return to the 'root' prompt in the main menu.

#### Step 4 Select frequency of maximum mains (line) rejection

Scroll through the main menu until 'Cond' is displayed and press *P* which will result in the instrument displaying '0000' with the most significant digit flashing. To prevent accidental adjustment the Cond sub-menu is protected by the code word 'SurE' which should be entered character by character using the *Up* and *Down* buttons plus *P* to move control to the next digit. Note: S is entered as 5. When 'SurE' has been entered pressing *E* will result in the 'FrE' prompt. Press *P* to enter the function and using the *Up* or *Down* buttons select '50'. Finally, press *E* twice to return to the 'Cond' prompt in the main menu.

#### Step 5 Define function of P push-button

Select 'C--P' from the main menu and press *P* to reveal the function of the *P* button in the operating mode. Select percentage 'PC' and return to the main menu by pressing *E*.

#### Step 6 Define rate display resolution

Select 'rESn' from the main menu and press *P* to reveal the current resolution of the rate display. Using the *Up*, and *Down* push buttons select a resolution of '1' and return to the 'rESn' prompt in the main menu by pressing *E*.

#### Step 7 Position rate & total decimal points

Select 'd.P.' from the main menu and press *P*. The rate and total displays will be activated with one digit of the total display flashing. Press the *Up* or *Down* push-button until the second least significant digit of the total display and following decimal point are flashing. This gives the required total display resolution of 0.1

Press *P* to move control to the rate display. Using the *Up* or *Down* push-button move the flashing digit to the least significant position (right hand side) which will result in no decimal point being displayed.

Finally press *E* to return to the 'd.P.' prompt in the main menu.

### Step 8 Calibrate the rate display

Scroll through the main menu until 'CAL' is displayed. Press *P* and the instrument will request a 4mA input by displaying 'ZErO'. Set the input current to 4.0000mA and press *P* again which will reveal the existing rate display. Using the *Up*, *Down* *P* push-buttons enter the required zero display of 0000. Press *E* to enter this calibration figure and return the instrument to the 'ZErO' prompt.

Press the *Up* push-button and the instrument will request a 20mA input by displaying 'SPAn'. Set the input current to 20.0000mA and again press *P* which will reveal the existing rate display at 20mA. Using the *Up*, *Down* and *P* push-buttons enter the required display of 1100.

Press *E* to enter this calibration figure and return the instrument to the 'SPAn' 'prompt' and again to return to the 'CAL' prompt in the main menu.

### Step 9 Define the timebase

In this example the rate display represents flow per minute so it is necessary to set the instrument timebase to 60. This will divide the rate display by 60 to provide the correct total display.

Select 't-BASE' from the main menu and press *P* to reveal the current setting. Using the *Up* and *Down* push buttons select 'tb - 60' and then return to the main menu by pressing *E*.

### Step 10 Define the totaliser scaling factor

In this example the rate display is in litres per minute but the total display is required in cubic metres:

$$\text{SCALE-t} = \frac{\text{Units of rate display}}{\text{Units of total display}}$$

There are 1,000 litres in a cubic metre thus:

$$= \frac{\text{litres}}{\text{cubic metres}}$$

$$= \frac{1 \text{ litre}}{1/(1000) \text{ litres}}$$

$$\text{SCALE-t} = 1000$$

From the main menu select 'SCALE-t' and press *P* to reveal the current five digit dividing factor. Using the *Up* and *Down* buttons to adjust the flashing digit, and the *P* button to transfer control between digits, set 'SCALE-t' to 1000.0

The position of the decimal point is defined by moving the flashing digit to the second least significant position and operating the *Up* and *Down* buttons simultaneously.

When 'SCALE-t' has been set to 1000.0 press *E* to return to the main menu.

### Step 11 Define percentage cut-off

Totalisation is to be inhibited at flow rates below 1% of maximum flow. To define this cut-off point select 'CLIP-OFF' from the main menu and press *P* which will reveal the existing setting. Using the *Up* and *Down* buttons select 1 and return to the main menu by pressing *E*.

### Step 12 Reset the grand total to zero

To reset the grand total to zero select 'CLr. Gtot' from the main menu and press *P* which will cause the instrument to display 'Clr. no'. Toggle this to 'CLr. YES' using the *Up* or *Down* push-buttons and press *P* which will result in a '0000' prompt. Using the *Up*, and *Down* buttons and the *P* button to move to the next digit, confirm the request by entering the password 'SurE'. Note: S is entered as 5. Pressing *E* will then reset the grand total counter to zero and return the instrument to the 'CLr. Gtot' prompt in the main menu.

**Step 13 Set the security code**

Defining a security code prevents unauthorised access to the programme functions. Select 'COdE' from the main menu and press *P* which will reveal the existing security code. Using the *Up* and *Down* buttons enter the new code 1209 digit by digit. The *P* button will transfer control between digits. When the new code has been entered, press *E* to return to the main programme menu.

**Step 14 Return to the operating mode**

Following completion of programming and calibration, return the instrument to the operating mode by pressing *E*. All the BA354D programming functions will now be stored in permanent memory and protected from accidental adjustment by the security code.

**Step 8 Calibrate the rate display**

Scroll through the main menu until 'SEt' is displayed. Press *P* and the instrument will display 'ZEro', pressing *P* will reveal the existing rate display at 4mA. Using the *Up*, *Down* and *P* push-buttons enter the required zero display of 0.0 Press *E*, to return to the 'ZEro' prompt.

Press *the Up* push-button and the instrument will display 'SPAn'. Pressing *P* again will reveal the existing display at 20mA. Using the *Up*, *Down* and *P* push-buttons enter the required display of 1100

**Steps 9 to 14**

As previous calibration example in section 7.1

## 7.2 Calibration example

### Using the internal references

In this example the internal references within the BA354D are used to calibrate the rate display. Except for steps 1, 2 and 8 the procedure is identical to that in the previous example in section 7.1 The advantages of using the internal references are that the instrument does not have to be disconnected from the measurement loop and no calibration equipment is required.

**Steps 1&2 Enter the programming mode**

The BA354D may be recalibrated without disconnection from the 4/20mA measurement loop. With any input current between 4 and 20mA put the instrument in the programming mode by simultaneously pressing *P* and *E*. Assuming a security code has not already been entered the instrument will respond by displaying 'root' which is the first function in the main menu.

**Steps 3 to 7**

Perform as described in previous calibration example in section 7.1

## 8. MAINTENANCE

### 8.1 Fault finding during commissioning

If a BA354DC fails to function during commissioning the following procedure should be followed:

Symptom	Cause	Check
No display	Incorrect wiring	There should be 1V between terminals 1 & 3 with terminal 1 positive
No display and no voltage between terminals 1 & 3	Incorrect wiring or no power supply.	Check wiring and confirm that a 4/20mA current is flowing in the loop.
Rate displays flashing 1	Positive over-range	The rate display has been incorrectly calibrated & is trying to display a number greater than 20500.
Rate displays flashing -1	Negative over-range	Input current is less than approximately 3.4mA.
Unstable rate display	4/20mA current has a large ripple content	Eliminate source of electrical noise . Reduce resolution of the rate display to mask flow noise
Unable to enter programme mode	Incorrect security code	Enter the correct security code or fit security link in override position. See Fig 8

### 8.2 Fault finding after commissioning

#### ENSURE PLANT SAFETY BEFORE STARTING MAINTENANCE

**Live maintenance is permitted on intrinsically safe equipment installed in a hazardous area, but only certified test equipment should be used unless a gas clearance certificate is available.**

If a BA354D fails after it has been functioning correctly, the following table may help to identify the cause of the failure.

Symptom	Cause	Check
No display and no voltage between terminals 1 & 3	No power supply.	Confirm that a 4/20mA current is flowing in the loop.
Unstable rate display	4/20mA current is noisy or the flow signal is unstable	Eliminate source of electrical noise . Reduce resolution of the rate display to mask flow noise
Incorrect calibration	Digital filter FrE has been changed after indicator was calibrated	Recalibrate indicator with digital filter FrE set to required frequency
Unable to enter programme mode	Incorrect security code	Enter the correct security code or fit security link in override position. See Fig 8

If this procedure does not reveal the cause of the fault, it is recommended that the instrument is replaced. Alternatively the electronic assembly may be exchanged as described in section 8.3

### 8.3 Servicing

To simplify servicing all BA354D indicators use a common display assembly which can be easily replaced on site. Depending upon the accessories fitted, one spare display assembly may be used to repair any BA354D which fails. The exchange may be made without disconnecting power, the 4/20mA loop will continue to function, but the rate totaliser voltage drop will increase from 1 to 4V when the display assembly is removed.

To exchange the display assembly remove the terminal cover by unscrewing the two 'A' screws which will reveal two concealed 'D' screws. Unscrew all four 'D' screws and carefully lift off the front of the instrument as shown in Fig 4. The instrument assembly is secured by four Pozi headed screws which should be removed. If the instrument is fitted with a backlight or alarms the fly-leads connecting the accessory boards to the terminals should be un-plugged. The replacement display assembly may then be installed and the enclosure reassembled.

If after replacement of the display assembly the instrument still does not function, it is likely that the fault is within the protection components on the terminal assembly. Terminal assemblies may be exchanged on site providing the replacement includes terminals for any accessories fitted to the display assembly i.e. terminals for backlight and alarms.

We recommend that faulty instruments and instrument assemblies are returned to BEKA associates or to our local agent for repair.

#### **8.4 Routine maintenance**

The mechanical condition of the instrument and electrical calibration should be regularly checked. The interval between inspections depends upon environmental conditions. We recommend that initially instrument calibration should be checked annually.

#### **8.5 Guarantee**

Instruments which fail within the guarantee period should be returned to BEKA associates or our local agent. It is helpful if a brief description of the fault symptoms is provided.

#### **8.6 Customer comments**

BEKA associates is always pleased to receive comments from customers about our products and services. All communications are acknowledged and whenever possible, suggestions are implemented.

## 9. ACCESSORIES

### 9.1 Units of measurement and instrument identification

All BA354D indicators are fitted with a display label behind the armoured glass window. This label can be supplied printed with any units of measurement and tag information specified at the time of ordering. Alternatively the information may be added on-site via an embossed strip, dry transfer or a permanent marker.

To gain access to the display label remove the terminal cover by unscrewing the two 'A' screws which will reveal two concealed 'D' screws. Remove all four 'D' screws and carefully lift off the front of the instrument - see Fig 4. Add the required legend to the display label, or replace with a new pre-printed label which are available from BEKA associates

The BA354D can also be supplied with a blank or custom engraved stainless steel plate secured to the instrument terminal cover by tamperproof screws. The plate can accommodate:

1 row of 9 alphanumeric characters 10mm high

or 1 row of 11 alphanumeric characters 7mm high

or 2 rows of 18 alphanumeric characters 5mm high

### 9.2 Alarms

The BA354D can be supplied with two solid state single pole outputs which may be independently programmed as high or low, rate or total alarms with normally open or normally closed outputs.

Fig 9 illustrates the conditions available for a rate alarm and shows which are fail safe, i.e. output is in the alarm condition (open) when the 4/20mA input current is zero. Similarly, when programmed as a total alarm, the output should be open in the alarm condition.

#### WARNING

**These alarm outputs should not be used for critical safety applications such as a shut down system.**

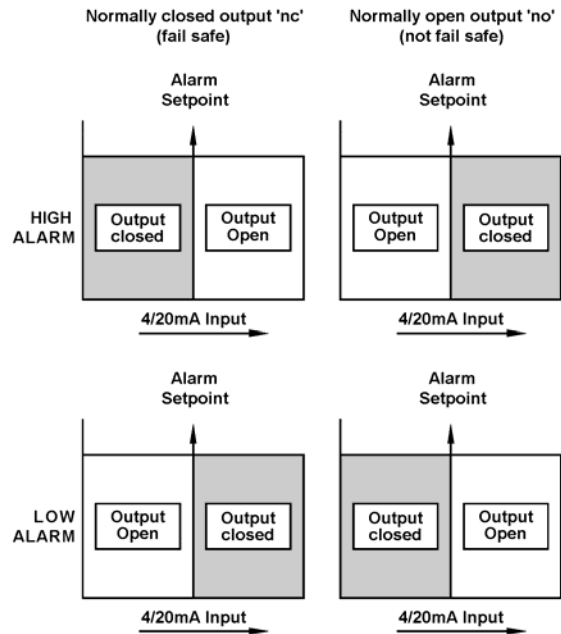

Fig 9 Rate alarm outputs

The status of each alarm is indicated by an alarm annunciator on the instrument display. If an alarm delay or silence time has been selected the annunciator will flash during the delay or silence period.

Programmable functions for each alarm include adjustable setpoint, alarm delay time and alarm accept time. Hysteresis may be added when programmed as a rate alarm.

The BA354D total display is up-dated and compared with the programmed alarm setpoint once per second. This may result in the total alarm being delayed for up to a second after the total has exceeded the setpoint.

#### 9.2.1 Solid state output

Each alarm has a galvanically isolated single pole solid state switch output as shown in Fig 10. The outputs are polarised and current will only flow in one direction. Terminals 8 and 10 should be connected to the positive side of the supply.

$$R_{on} = 5 + 0.6V$$

$$R_{off} = \text{greater than } 180k$$

Note: Because of the series protection diode some test meters may not detect a closed alarm output

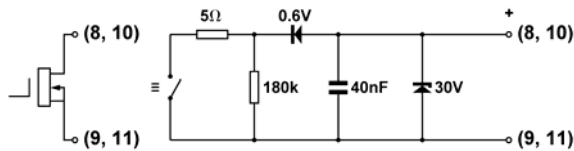

Fig 10 Equivalent circuit of each alarm output

### 9.2.2 Intrinsic safety

Each of the two alarm outputs is a separate galvanically isolated solid state switch. The EC-Type Examination Certificate specifies that under fault conditions the voltage, current and power at each alarm output will not exceed those specified for *simple apparatus* in Clause 5.4 of EN50020:1994. This allows each of the BA354D alarm outputs to be connected to any intrinsically safe circuit protected by a Zener barrier or galvanic isolator providing that the output parameters of each circuit do not exceed:

$U_o$	28V dc
$I_o$	200mA
$P_o$	0.85W

No system certificate has been issued for the BA354D alarm outputs, as the system certificate for the circuit to which the alarms are connected remains valid.

The maximum equivalent capacitance and inductance of each BA354D alarm output is:

$C$	=	40nF
$L$	=	20μH

To determine the maximum permissible cable parameters, the equivalent alarm output parameters must be subtracted from the maximum cable capacitance and inductance specified by the system certificate of the circuit connected to each alarm.

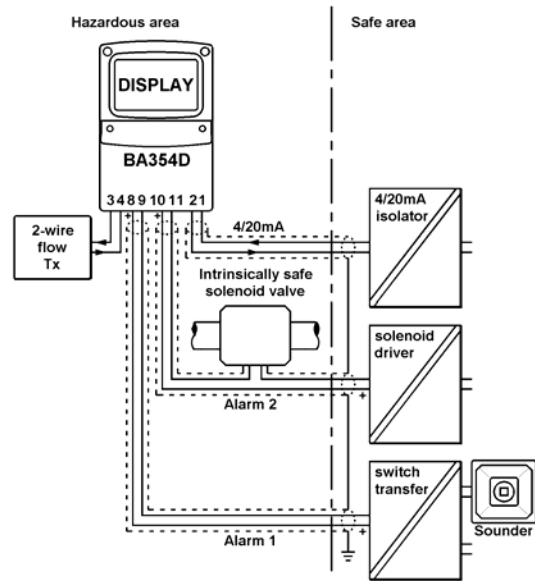

Fig 11 Typical alarm application

### 9.2.3 Programming and adjustment

When a BA354D is supplied with alarms the main programme menu is extended as shown in Fig 12. The two alarm functions appear between the 'C--P' and the 'SCALE-t' functions, and each alarm may be programmed as a rate or a total alarm.

For simplicity Fig 12 only shows the programmable functions on the rate option of alarm AL1. Alarm 2 and the total options are identical except that the total alarms do not have hysteresis.

The following table summarises each of the alarm programme functions and includes a cross reference to more detailed information. Again only the functions on alarm AL1 are listed.

## Summary of programmable alarm functions

<u>Display</u>	<u>Description of function</u>
'EnbL'	<p><b>Alarm enable</b> Enables or disables the alarm function without changing the alarm parameters. See section 9.2.4</p>
'tYPE'	<p><b>Type of alarm</b> Defines whether the alarm operates on the rate or total display. See section 9.2.5</p>
'SPr1' or 'SPt1'	<p><b>Alarm setpoint 1</b> Adjusts the alarm setpoint. The alarm is activated when the rate or total display equals the setpoint. See section 9.2.6</p>
'HI.LO'	<p><b>Alarm function</b> Defines whether the alarm has a high or low function See section 9.2.7</p>
'no.nc'	<p><b>Normally open or normally closed output</b> Determines whether the single pole alarm output is open or closed in the non alarm condition. See section 9.2.8</p>
'HStr'	<p><b>Hysteresis</b> Adjusts the alarm hysteresis. Only available on rate alarms. See section 9.2.9</p>
'dELA'	<p><b>Alarm delay time</b> Adjusts the delay between the display equalling the setpoint and the alarm output being activated. See section 9.2.10</p>
'SIL'	<p><b>Alarm silence time</b> Defines the time that the alarm output remains in the non-alarm condition following acceptance of an alarm. See section 9.2.11</p>
'AcSP'	<p><b>Access setpoint</b> Sub-menu which enables direct access to the alarm setpoints from the display mode and defines a separate security code. See section 9.2.12</p>

### 9.2.4 Alarm enable: EnbL

This function allows the alarm to be enabled or disabled without altering any of the alarm parameters. To check or change the function select 'EnbL' from the alarm menu and press *P* which will reveal the current setting. The function can be changed by pressing the *Up* or *Down* button followed by the *E* button to return to the alarm menu.

### 9.2.5 Type of alarm: tYPE

This function conditions the alarm to operate on the rate or total display. Alarm 1 and Alarm 2 may both be rate or total alarms, or one may be conditioned for rate and the other for total.

To check or change the type of alarm, select 'tYPE' from the alarm menu and press *P* which will reveal the current setting. The function can be changed by pressing the *Up* or *Down* button followed by the *E* button to return to the alarm menu.

**Note:** To prevent accidental conditioning the alarm must be re-enabled after the alarm function has been changed – see 9.2.4.

### 9.2.6 Setpoint adjustment: SPx1 and SPx2

The rate alarm setpoints SPx1 and SPx2 may be positioned anywhere between 0 and 20000 providing this corresponds to an input current between 3.8 and 20.2mA. The total alarm setpoint SPt1 and SPt2 may be positioned anywhere between 00000000 and 99999999

To adjust the setpoint select 'SPr1' or 'SPt1' from the alarm menu. Note: 'SPr1' is displayed when a rate alarm has been selected and 'SPt1' a total alarm has been selected. Press *P* which will reveal the existing alarm setpoint. Each digit of the setpoint can be adjusted using the *Up* and *Down* push-buttons, and the *P* button to move to the next digit. The position of the decimal point is determined by the d.P. function. When the required setpoint has been entered press *E* to return to the alarm menu.

### 9.2.7 Alarm function: HI.LO

Each alarm can be conditioned as a high or low alarm. To check or change the alarm function select 'HI.LO' from the alarm menu and press *P* to reveal the current setting. The function can be changed by pressing the *Up* or *Down* buttons followed by the *E* button to return to the alarm menu.

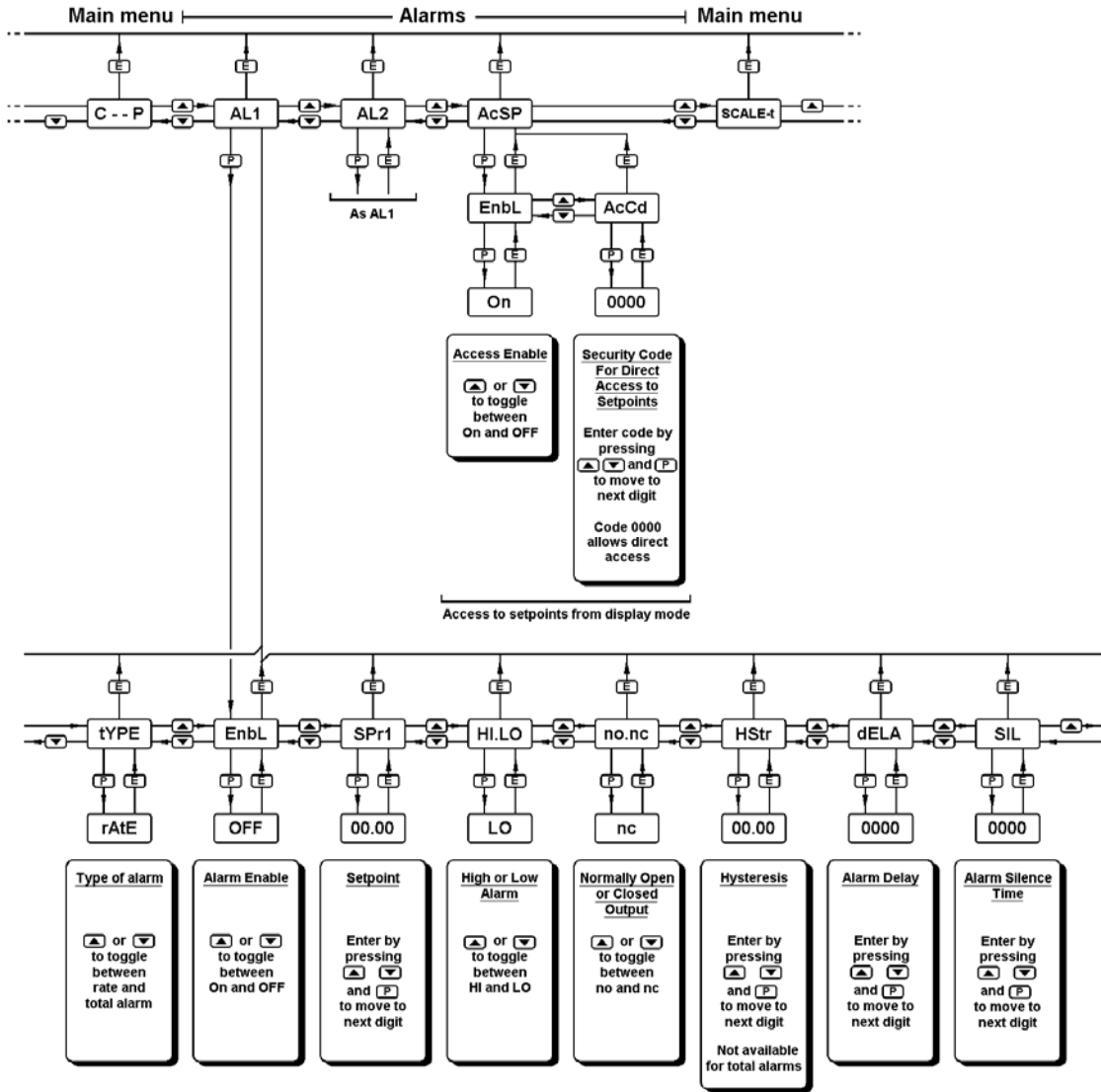

**9.2.8 Alarm output status: no.nc**

This function allows the alarm output to be open or closed in the alarm condition. When deciding which is required, care must be taken to ensure that the alarm output is fail safe. See Fig 9.

**CAUTION**

**When the 4/20mA supply is removed both alarm outputs will open irrespective of conditioning. Therefore for fail safe operation both alarm outputs should be programmed to be open in the alarm condition.**

To check the alarm output status select 'no.nc' from the alarm menu and press *P* to reveal the current setting. The function can be changed by pressing the *Up* or *Down* button followed by the *E* button to return to the alarm menu.

**9.2.9 Hysteresis: HStr**

Hysteresis is only available on rate alarms. During programming hysteresis is shown in the units of rate the BA354D has been calibrated to display.

To adjust the hysteresis, select 'HStr' from the alarm menu and press *P* which will reveal the existing figure. Each digit can be adjusted using the *Up* and *Down* push-buttons, and the *P* button to move to the next digit. When the required hysteresis has been entered, press *E* to return to the alarm menu.

e.g. A BA354D calibrated to display a flow of 0 to 5000, with a high alarm set at 4000 and hysteresis of 100 will perform as follows:

High alarm will be activated when flow equals or exceeds 4000, but will not reset until the flow falls below 3900.

### 9.2.10 Alarm delay: dELA

This function enables activation of the alarm output to be delayed for a fixed time following the alarm condition occurring. The delay can be programmed in 1 second increments up to 3600 seconds. If a delay is not required zero should be entered. To adjust the delay select 'dELA' from the alarm menu and press *P* which will reveal the existing delay. Each digit of the delay can be adjusted using the *Up* and *Down* push-buttons, and the *P* button to move to the next digit. When the required delay has been entered, press *E* to return to the alarm menu. The alarm annunciator will start flashing immediately an alarm occurs and continue for the delay time after which the alarm output will be activated.

### 9.2.11 Alarm silence time: SIL

This function is primarily intended for use in small installations where the alarm output directly operates an annunciator such as a sounder. When the alarm silence time is set to any figure other than zero, the *P* push-button becomes an alarm accept button. After an alarm has occurred, operating the *P* button will cause the alarm output to revert to the non-alarm condition for the programmed alarm silence time. The instrument alarm annunciator will continue to display an alarm after it has been accepted and silenced. The alarm silence time may be adjusted between 0 and 3600 seconds in 1 second increments.

To adjust the alarm silence time select 'SIL' from the alarm menu and press *P* which will reveal the existing time. Each digit can be adjusted using the *Up* and *Down* push-buttons, and the *P* button to move to the next digit. When the required time has been entered press *E* to return to the alarm menu.

When an alarm is silenced the alarm annunciator will flash until the silence time expires.

### 9.2.12 Access Setpoint: AcSP

This function controls a separate menu which provides direct access to the alarm setpoints when the instrument is in the display mode. See section 9.2.13 for a full description. An operator may therefore adjust the alarm setpoints without having access to the programme and alarm menus. Further protection is provided by a separate security code.

This direct access menu is enabled and a separate security code entered from the 'AcSP' function in the main programme menu as

shown in Fig 12. To change the menu parameters select 'AcSP' from the programme menu and press *P* which will display the enable prompt 'EnbL'.

Press *P* again to reveal if the direct access menu is 'On' or 'OFF'. The *Up* or *Down* buttons will toggle the display between the two conditions.

If 'OFF' is selected, the operator will not have access to the setpoints from the display mode. Return to the 'AcSP' prompt in the main menu by pressing *E* twice.

If 'On' is selected, the operator will have direct access to the alarm setpoints from the display mode via a separate optional security code. To define the four digit numerical code press *E* to return to the 'EnbL' prompt followed by the *Up* or *Down* button to select the access code prompt 'AcCd'. Pressing *P* will reveal the current security code. Each digit of the code may be changed by operating the *Up* and *Down* push-buttons, and the *P* button to move to the next digit. When the required code has been entered, press *E* twice to return to the 'AcSP' prompt in the Programme Menu.

Code 0000 will disable the security code allowing direct access to the setpoints by pressing the *P* and *Up* buttons simultaneously. New instruments with alarms are supplied with this function disabled and the security code set to 0000

### 9.2.13 Adjusting alarm setpoints from the display mode

Access to the two alarm setpoints from the indicator display mode is obtained by operating the *P* and *Up* push-buttons simultaneously as shown in Fig 13. If the setpoints are not protected by a security code the alarm setpoint prompt 'SPr1' or 'SPt1' will be displayed depending upon whether a rate or total alarm has been programmed. If the setpoints are protected by a security code, 'COde' will be displayed first. Pressing *P* again will enable the alarm security code to be entered digit by digit using the *Up* and *Down* buttons to change the flashing digit, and the *P* push-button to move to the next digit. If the correct code is entered pressing *E* will cause alarm setpoint prompt 'SPx1' to be displayed. Pressing the *Up* or *Down* button will toggle the display between the two alarm setpoint prompts 'SPx1' and 'SPx2'.

If an incorrect security code is entered, or a button is not pressed within ten seconds, the instrument will automatically return to the display mode.

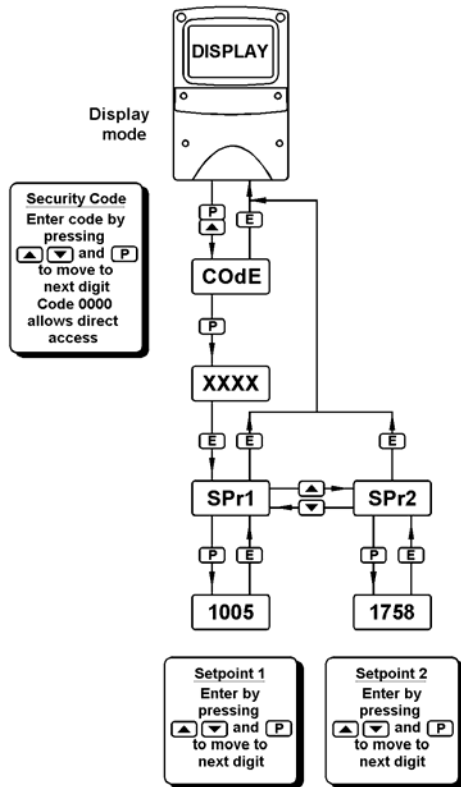

Fig 13 Setpoint adjustment from the display mode

To adjust an alarm setpoint select 'SP1' or 'SP2' and press *P* which will reveal the current setting. Each digit of the setpoint may be adjusted using the *Up* and *Down* push-buttons, and the *P* button to move to the next digit. When the required setpoint has been entered, pressing *E* will return the display to the 'SP1' or 'SP2' prompt from which the other setpoint may be selected, or the indicator may be returned to the display mode by pressing *E* again.

Direct access to the alarm setpoints is only available when the menu is enabled - see section 9.2.12

### 9.3 Display backlight

The BA354D can be supplied with LED backlighting to improve display contrast when the instrument is installed in a poorly illuminated area. The backlight is segregated from the measuring circuit and has been certified as a separate intrinsically safe circuit, but it does not comply with the requirements for *simple apparatus*. Systems certificates for use with Zener barriers and galvanic isolators have therefore been issued.

The backlight must be powered from the safe area via a Zener barrier or a galvanic isolator as shown in Fig 14. Any certified Zener barrier may be used, providing the output parameters do not exceed:

$U_o$	28V dc
$I_o$	159mA
$P_o$	0.8W
$C_i$	40nF
$L_i$	20 $\mu$ H

Alternatively a galvanic isolator may be used in place of the barrier. For UK installations only the galvanic isolators specified on the system certificate should be used.

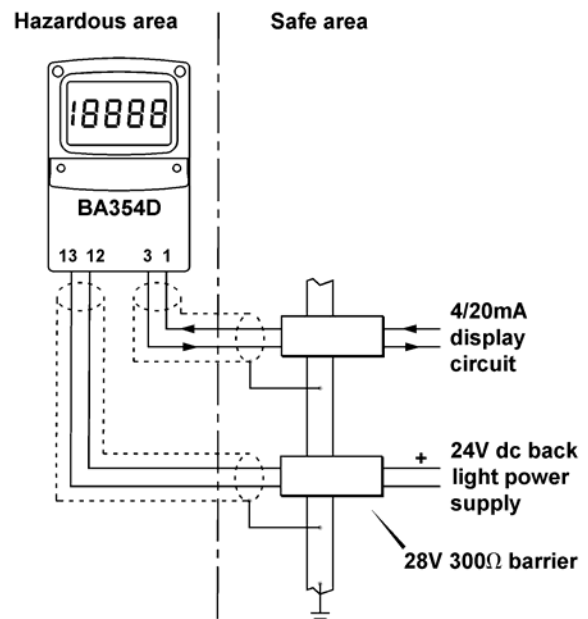

Fig 14 Backlight powered by Zener barrier

The display brilliance depends upon the current flowing through the backlight. This is determined by the supply voltage and the end-to-end resistance of the Zener barrier or output resistance of the galvanic isolator. Brilliance will not be significantly reduced until the current falls below 20mA.

$$\text{Backlight current} = \frac{V_{\text{supply}} - 18}{\text{End-to-end resistance of barrier\#}}$$

# or output resistance of galvanic isolator

#### 9.4 External push-buttons

For applications requiring frequent access to the programme menus the BA354D can be supplied with an external membrane keypad. These switches, which maintain the IP66 integrity of the enclosure, allow all functions to be controlled without removing either of the enclosure covers.

#### 9.5 Pipe mounting kits

Two pipe mounting kits are available for securing the BA354D to a horizontal or vertical pipe.

BA392D Stainless steel bracket secured by two worm drive hose clips for 60 to 80mm outside diameter pipes.

BA393 Heavy duty stainless steel bracket secured by a single 'V' bolt. Will clamp to any pipe with an outside diameter between 40 and 80mm.

#### 9.6 Stem mounting kit

The BA395 stem mounting kit comprises a short length of stainless steel conduit with a male M20 x 1.5 thread at both ends. Allows the BA354D to be mounted directly onto a flow transmitter.

## 10. INDEX

Subject	Section	Subject	Section
AC rejection 'FrE'	6.9.1	'LOC.rSEt'	6.15
'AcSP'	9.2.3; 9.2.12	Location	5.1
Alarms optional	9.2	Maintenance	8.0
access 'AcSP'	9.2.3; 9.2.12	routine	8.4
contacts 'no.nc'	9.2.3; 9.2.8	Mounting kits	
delay time 'dELA'	9.2.3; 9.2.10	pipe	9.5
enable 'EnbL'	9.2.3; 9.2.4	stem	9.6
function 'HI.LO'	9.2.3; 9.2.7		
hysteresis 'HStr'	9.2.3; 9.2.9	'no.nc'	9.2.3; 9.2.8
programming	9.2.3	Notified Body	1.0
setpoint 'SPxx'	9.2.3; 9.2.6		
silence time 'SIL'	9.2.3; 9.2.11	Over & under range	6.17
solid state output	9.2.1		
type 'tYPE'	9.2.3; 9.2.5	Push-buttons	
ATEX Directive	1.0; 3.1; 3.5	<i>Down</i>	2.1
Dust certification	Appendix 1	<i>E</i>	2.1
Backlight optional	9.3	<i>P</i>	2.1; 6.3; 6.12
Calibration		<i>Up</i>	2.1
structure	6.1; Fig 7A & B	External optional	9.4
programme access	6.2	Rate display	2.2
rate display	6.3; 6.7; 6.8	Reset	3.3; 4.3
examples	7.0; 7.1; 7.2	local 'LOC.rSEt'	6.15
'CLIP-OFF'	6.3; 6.14	Remote indication	4.2
Clipoff 'CLIP-OFF'	6.3; 6.14	'rESn'	6.3; 6.5
Decimal points 'd.P.'	6.3; 6.6	'SCALE-t'	6.3; 6.13; Fig 6
'dELA'	9.2.3; 9.2.10	Security code 'Code'	6.3; 6.16
Display		Servicing	8.3
resolution 'rESn'	6.3; 6.5	'SIL'	9.2.3; 9.2.11
exchange rate & total	6.6	'SPxx'	9.2.3; 9.2.6
'd.P.'	6.3; 6.6	Square root extractor 'root'	6.3; 6.4
Dust certification	Appendix 1		
'EnbL'	9.2.3; 9.2.4	't-bASE'	6.3; 6.11; Fig 6
Fault finding		T rating	3.4
during commissioning	8.1	Terminal numbers	Fig 5
after commissioning	8.2	Timebase 't-bASE'	6.3; 6.11; Fig 6
Flow indicator	2.2	Total	
Flow transmitter loops	4.1	display	2.2
Galvanic isolators	4.0	scale factor 'SCALE-t'	6.3; 6.13; Fig 6
Gas groups	3.4	'tYPE'	9.2.3; 9.2.5
Grand total	2.1	Units of measurement	9.1
clear	6.3; 6.10	Zener barriers	4.0
Guarantee	8.5	Zones	3.4
'HI.LO'	9.2.3; 9.3.7		
'HStr'	9.2.3; 9.2.9		
Input 4/20mA	3.2		
Internal references	6.3; 6.9		
Installation	5.2		
Instrument identification	9.1		
Intrinsic safety	1.0; 3.0; 9.2.2;		
	9.3		

## Appendix 1 ATEX dust certification

### A1.0 ATEX dust certification

In addition to ATEX certification permitting installation in explosive gas atmospheres which is described in the main section of this instruction manual, the BA354D is available ATEX certified for use in the presence of combustible dusts. If ATEX dust certification is required it must be requested when the BA354D totaliser is purchased.

#### WARNING

**Before installing a BA354D totaliser in the presence of a combustible dust, ensure that the certification information label which is located on the top of the instrument specifies dust certification - see section A1.2**

### A1.1 Zones and Maximum Surface Temperature

The BA354D has been ATEX certified as Group II, Category 1 GD apparatus Tamb = -20 to 60°C, with a Maximum Surface Temperature of 80°C. When installed as specified by EN 50281 Part 1-2 'Selection, installation and maintenance of electrical apparatus protected by enclosures', the totaliser may be installed in:

- Zone 20 explosive atmosphere in the form of a cloud of combustible dust in air is continuously present, or for long periods or frequently.
- Zone 21 explosive atmosphere in the form of a cloud of combustible dust in air is likely to occur occasionally in normal operation.
- Zone 22 explosive atmosphere in the form of a cloud of combustible dust in air is not likely to occur in normal operation, but if it does occur, will only persist for a short period.

Be used with dusts having a Minimum Ignition Temperature of:

Dust cloud	120°C
Dust layer on BA354D up to 5mm thick	155°C
Dust layer on BA354D over 5mm thick.	Refer to EN500281 part 1-2

At an ambient temperature between -20 and +60°C

### A1.2 Certification Label Information

The certification label is fitted in a recess on the top outer surface of the enclosure. It shows the ATEX dust certification information including the maximum surface temperature and ingress protection, plus the ATEX gas certification information. Non European information may also be shown.

<b>BA354D Loop Powered Rate Totaliser</b>	
CE 0359 (Ex)	II 1 G Tamb = -40°C to +60°C II 1 GD T80°C Tamb = -20°C to +60°C IP66
EEx ia IIC T5 ITS00ATEX2009	
<small>Year of manufacture shown within terminal compartment</small>	
<small>BEKA associates Ltd Hitchin England www.beka.co.uk</small>	

The instrument serial number and date of manufacture are recorded on a separate label inside the terminal compartment.

### A1.3 Calibration & maintenance

The ATEX dust certification relies on the totaliser enclosure being dust-tight. Therefore the control and terminal covers should only be removed when dust can not enter the instrument enclosure. Before replacing the control and terminal covers ensure that the sealing gaskets are undamaged and are free from foreign bodies.