

**BA327C & BA328C
intrinsically safe
loop-powered
4½ digit panel
mounting indicators**

Issue 6

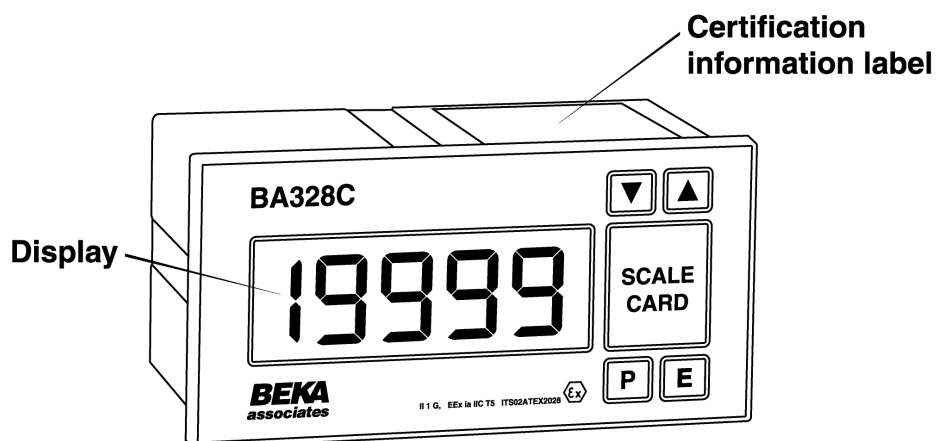

Issue: 6
12th February 2008

1. Description**2. Operation**

- 2.1 Controls

3. Intrinsic safety certification

- 3.1 ATEX certificate
- 3.2 4/20mA input
- 3.3 Zones, gas groups & T rating
- 3.4 Certification label information

4. System Design for Hazardous Areas

- 4.1 Transmitter loops
- 4.2 Remote indication

5. Installation

- 5.1 Location
- 5.2 Installation procedure
- 5.3 EMC

6. Programming and Calibration

- 6.1 Summary of programmable functions.
- 6.2 Root extractor
- 6.3 Resolution
- 6.4 Position of decimal point
- 6.5 Calibration using an external current source.
- 6.6 Calibration using internal references.
- 6.7 Conditioning sub-menu
 - 6.7.1 AC rejection
 - 6.7.2 Calibration of internal references.
- 6.8 Function of the *P* push-button
- 6.9 Security code
- 6.10 Over and under-range

7. Calibration Example

- 7.1 Using an external calibrator
- 7.2 Using the internal calibrator

8. Maintenance

- 8.1 Fault finding during commissioning
- 8.2 Fault finding after commissioning
- 8.3 Servicing
- 8.4 Routine maintenance
- 8.5 Guarantee
- 8.6 Customer comments

9. Accessories

- 9.1 Scale card
- 9.2 Tag strip
- 9.3 Alarms
 - 9.3.1 Solid state output
 - 9.3.2 Intrinsic safety
 - 9.3.3 Programming and adjustment.
 - 9.3.4 Alarm enable
 - 9.3.5 Setpoint adjustment
 - 9.3.6 Alarm function
 - 9.3.7 Alarm output status
 - 9.3.8 Hysteresis
 - 9.3.9 Alarm delay
 - 9.3.10 Alarm silence time
 - 9.3.11 Access setpoint
 - 9.3.12 Adjusting alarm setpoints from display mode.
- 9.4 Lineariser
 - 9.4.1 Calibration using an external source.
 - 9.4.2 Calibration using internal reference.
- 9.5 Tare function
- 9.6 Display backlight
 - 9.6.1 Separately powered
 - 9.6.2 Loop powered backlight

Appendix 1 Installation in USA**Appendix 2** IECEx Certification

The BA327C & BA328C are CE marked to show compliance with the European Explosive Atmospheres Directive 94/9/EC and the European EMC Directive 89/336/EEC

1. DESCRIPTION

The BA327C and BA328C are 4½ digit intrinsically safe loop powered digital indicators which display the current flowing in a 4/20mA loop in engineering units. Both instruments introduce less than a 1.1V drop which allows them to be installed into almost any 4/20mA current loop. No additional power supply or battery is required.

The two indicators are electrically similar, but have different size displays and enclosures.

Model	Display height	Bezel size
BA327C	10mm	96 x 48mm
BA328C	20mm	144 x 72mm

The main application of the BA327C and BA328C is to display a measured variable or control signal in a hazardous process area. The zero and span of the display are independently adjustable so that the indicators can be calibrated to display any variable represented by the 4/20mA current, e.g. temperature, flow, pressure or level.

The BA327C and BA328C have been certified intrinsically safe by ITS Testing and Certification Ltd to the European ATEX Directive 94/9/EC. The EC-Type Examination certificate specifies that under fault conditions the voltage, current and power at the input terminals of each instrument will not exceed those specified for *simple apparatus* in Clause 5.4 of EN50020:1994.

The BA327C and BA328C are also FM approved for use in the USA, this approval is described in Appendix 1.

International IECEx certification is described in Appendix 2.

2. OPERATION

Fig 1 shows a simplified block diagram of both models. The 4/20mA input current flows through resistor R1 and forward biased diode D1. The voltage developed across D1, which is relatively constant, is multiplied by a switch mode power supply and used to power the instrument. The voltage developed across R1, which is proportional to the 4/20mA input current, provides the input signal for the analogue to digital converter.

Each time a 4/20mA current is applied to the instrument, initialisation is performed. After a short delay the following display sequence occurs:

-1.8.8.8.8 Display test in which all segments of the display are activated for 0.5 seconds.

Blank display For 0.5 seconds.

Decimal points For 3 seconds. cycled

Input current display in engineering units. Using calibration information stored in instrument memory.

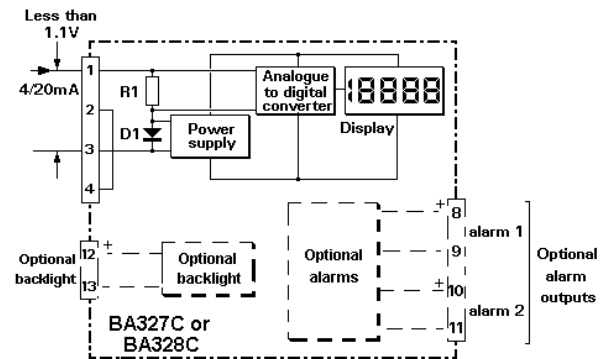

Fig 1 Simplified block diagram of BA327C and BA328C

2.1 Controls

The BA327C and BA328C are controlled and calibrated via four push-button switches. In the display mode these switches have the following functions:

- P** While this button is pushed the indicator will display the input current in mA, or as a percentage of the instrument span depending upon how the indicator has been programmed. When the button is released the normal display in engineering units will return. The function of this push-button is modified when alarms or a tare function are fitted to the indicator.
- Down** While this button is pushed the indicator will display the number which the indicator has been calibrated to display with a 4mA input. When released the normal display in engineering units will return.
- Up** While this button is pushed the indicator will display the number which the indicator has been calibrated to display with a 20mA input. When released the normal display in engineering units will return.
- E** No function in the display mode.

3. INTRINSIC SAFETY CERTIFICATION

3.1 ATEX certificate

The BA327C and BA328C have been issued with an EC-Type Examination Certificate number ITS02ATEX2028 by Notified Body ITS Testing and Certification Ltd. This confirms compliance with the European ATEX Directive for Group II, Category 1G equipment, EEx ia IIC T5. The instruments bear the Community Mark and, subject to local codes of practice, may be installed in any of the European Economic Area (EEA) member countries. ATEX certificates are also acceptable for installations in Switzerland. This manual describes installations which conform with EN60079:Part 14. When designing systems for installation outside the UK the local Code of Practice should be consulted.

3.2 4/20mA input

In Europe, sources of energy which do not generate more than 1.5V; 100mA, or 25mW are for intrinsic safety purposes considered to be *simple apparatus*.

Although the BA327C and BA328C indicators do not themselves comply with the requirements for *simple apparatus*, the EC-Type Examination Certificate specifies that under fault conditions the voltage, current and power at the 4/20mA input terminals 1 & 3 will not exceed those specified for *simple apparatus*. This allows the BA327C and BA328C to be connected into any intrinsically safe circuit protected by a EEx ia IIC certified Zener barrier or galvanic isolator providing the output parameters of the circuit do not exceed:

$$\begin{aligned} U_o &= 30V \text{ dc} \\ I_o &= 200\text{mA} \\ P_o &= 0.85W \end{aligned}$$

The EC-Type Examination Certificate specifies that the maximum equivalent capacitance and inductance between the two 4/20mA input terminals 1 and 2 is:

$$\begin{aligned} C_i &= 20\text{nF} \\ L_i &= 10\mu\text{H} \end{aligned}$$

To determine the maximum permitted cable parameters, these figures should be subtracted from the maximum cable capacitance and inductance permitted by the certificate for the loop into which the indicator is installed.

3.3 Zones, gas groups and T rating

The BA327C and BA328C have been certified EEx ia IIC T5. When connected to a suitable system the indicator may be installed in:

- Zone 0 explosive gas air mixture continuously present.
- Zone 1 explosive gas air mixture likely to occur in normal operation.
- Zone 2 explosive gas air mixture not likely to occur, and if it does will only exist for a short time.

Be used with gases in groups:

- Group A propane
- Group B ethylene
- Group C hydrogen

Having a temperature classification of:

- T1 450°C
- T2 300°C
- T3 200°C
- T4 135°C
- T5 100°C

At ambient temperatures between -40 and +60°C. Note: Operation only specified between -20°C and +60°C.

This allows both instruments to be installed in all Zones and to be used with most common industrial gases.

3.4 Certification label information

The certification label is fitted in a recess on the top outer surface of the instrument enclosure. It shows the ATEX certification information, instrument serial number, year of manufacture plus BEKA associates' name and location. Non European certification information may also be shown.

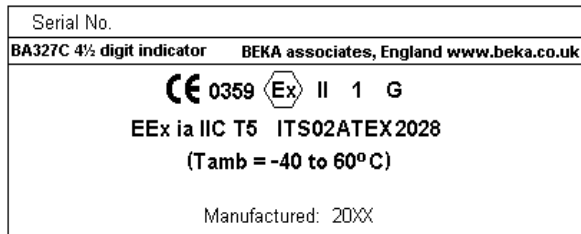

4. SYSTEM DESIGN FOR HAZARDOUS AREAS

4.1 Transmitter loops

BA327C and BA328C indicators may be connected in series with almost any intrinsically safe 4/20mA current loop and calibrated to display the measured variable or control signal in engineering units. There are two basic design requirements:

1. The intrinsic safety output parameters of the 4/20mA loop, which are defined by the Zener barrier or galvanic isolator, must be less than:

$$U_o = 30V \text{ dc}$$

$$I_o = 200mA$$

$$P_o = 0.85W$$

2. The loop must be able to tolerate the additional 1.1V required to operate the indicator.

Fig 2 illustrates a typical application in which an indicator is connected in series with a 2-wire transmitter protected by a Zener barrier.

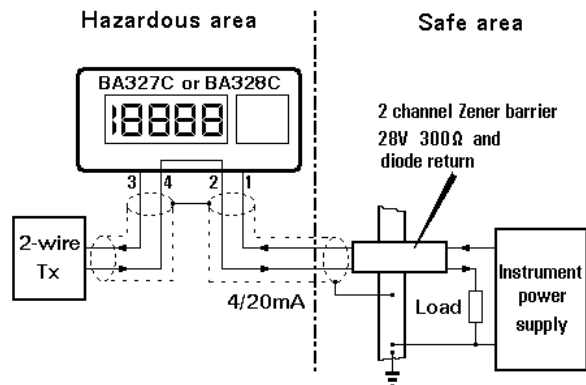

Fig 2 BA327C or BA328C in a transmitter loop

4.2 Remote indication

BA327C and BA328C indicators may be driven via an intrinsically safe interface from a 4/20mA safe area signal to provide a remote indication within a hazardous area. The type of interface is not critical, either a Zener barrier or a galvanic isolator may be used, providing that U_o , I_o and P_o are not exceeded.

If one side of the 4/20mA current loop may be earthed, a single channel Zener barrier provides the lowest cost protection. If the 4/20mA signal is not isolated, then two Zener barriers, a two channel Zener barrier or a galvanic isolator must be used. Again it is necessary to ensure that the voltage capability of the 4/20mA signal is sufficient to drive the indicator plus the voltage drop introduced by the intrinsically safe interface. Fig 3 shows the alternative circuits which may be used.

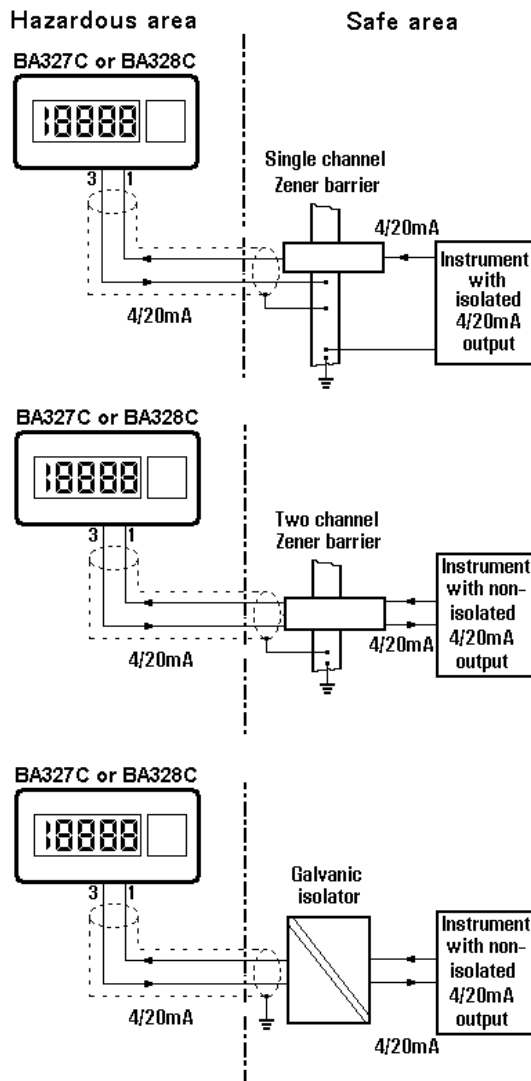

Fig 3 Alternative circuits for remote indication in a hazardous area

5. INSTALLATION

5.1 Location

BA327C and BA328C indicators are housed in robust aluminium enclosures with polyester front panels and Noryl bezels. The front of both instruments have IP65 protection, and a gasket seals the joint between the instrument enclosure and the panel. The indicators may be installed in any panel providing the environmental limits shown in the specification are not exceeded.

Figs 4A and 4B show the overall dimensions of each instrument and the required panel cut-out dimensions. To achieve an IP65 seal between the instrument enclosure and the instrument panel the smaller tolerance aperture must be used, and the BA328C must be secured with four mounting clips.

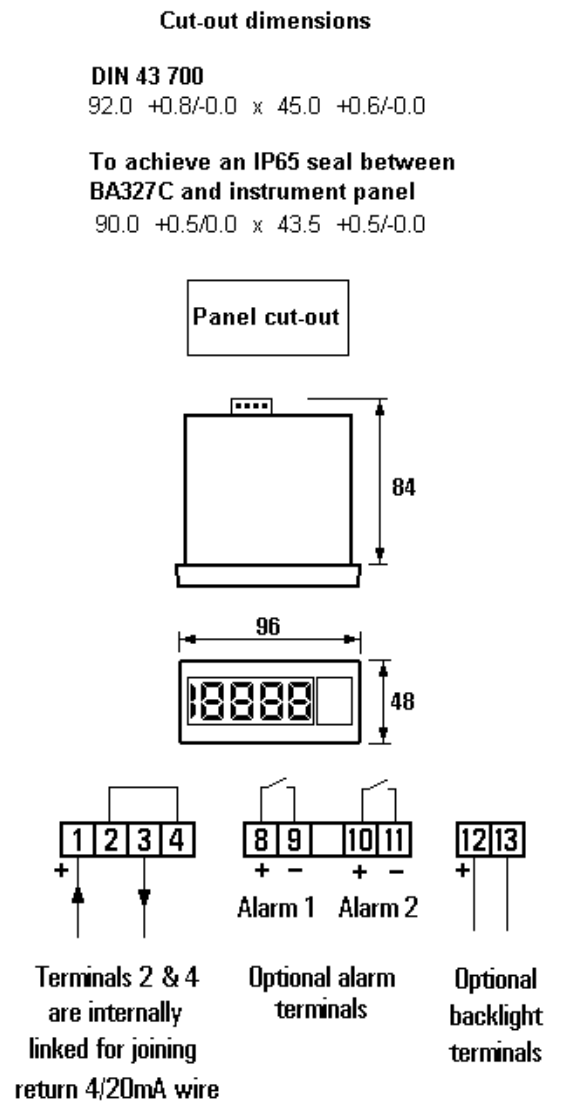

Fig 4A BA327C dimensions

Cut-out dimensions

DIN 43 700
 $138.0 \pm 1.0/-0.0 \times 68.0 \pm 0.7/-0.0$

To achieve an IP65 seal between BA328C and instrument panel

$136.0 \pm 0.5/-0.0 \times 66.2 \pm 0.5/-0.0$

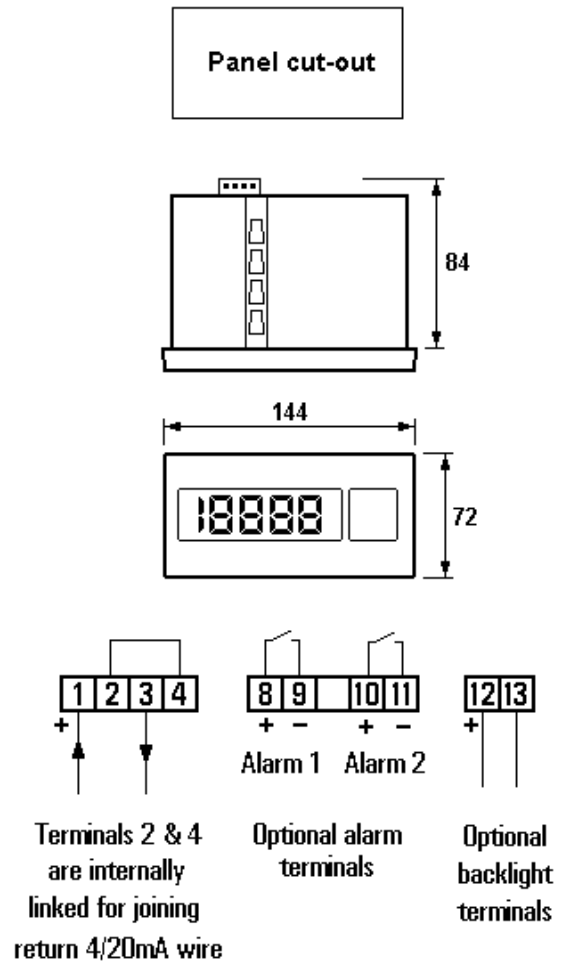

Fig 4B BA328C dimensions

5.2 Installation Procedure

- a. Insert the indicator into the panel aperture from the front of the panel.
- b. Fix two panel mounting clips to opposite sides of the instrument and tighten until the indicator is secure as shown in Fig 5. Four clips are required to achieve an IP65 between a BA328C and the instrument panel.

- c. Connect the panel wiring to the rear terminal block as shown in Fig 4. To simplify installation, the terminals are removable so that the panel wiring can be completed before the instrument is installed.

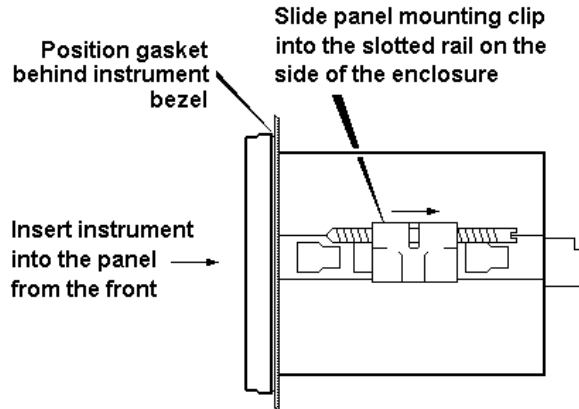

Fig 5 Fitting panel mounting clips

5.3 EMC

The BA327C and BA328C comply with the requirements of the European EMC Directive 89/336/EEC. For specified immunity all wiring should be in screened twisted pairs, with the screens earthed within the safe area. The indicator enclosure may be earthed locally by putting a tag under one of the rear panel fixing screws. EMC performance is shown in the instrument specification and copies of the report are available from BEKA associates.

6. PROGRAMMING AND CALIBRATION

The BA327C and BA328C are programmed and calibrated via four front panel push-buttons. All the functions are contained in an easy to use menu which is shown diagrammatically in Fig 6. Each function is summarised in section 6.1 which includes a reference to more detailed information. Although this simple menu driven system enables most adjustments to be made without repeated reference to this manual, we recommend that at least the summary of programmable functions in section 6.1 be read before starting recalibration.

When the indicator is fitted with alarms, linearisation or a tare function, additional functions are added to the menu. These accessories are described in section 9 of this manual.

Throughout this manual push-buttons are shown in italics e.g. *P* or *Up* push-button, and legends displayed by the indicator are shown within inverted commas e.g. 'CAL' and 'ALr2'. Access to the programme menu is obtained by operating the *P* and *E* push-buttons simultaneously. If the instrument is not protected by a security code the first parameter 'root' will be displayed. If a security code other than the default code 0000 has already been entered, the indicator will display 'COdE'. Press *P* to clear this prompt and enter the security code for the instrument using the *Up*, *Down* and *P* push-buttons. If the correct code has been entered pressing *E* will cause the first parameter 'root' to be displayed. If an incorrect code is entered the indicator will return to the display mode.

Once within the menu the required parameter can be reached by scrolling through the main menu using the *Up* and *Down* push-buttons as shown in Fig 6. When returning to the display mode following recalibration or changes to any parameters, the indicator will display circulating decimal points for a few seconds while the new information is stored in non-volatile memory.

All new BA327C and BA328C indicators are supplied calibrated as requested at the time of ordering. If calibration is not requested, the indicator will be set to display 0.00 with 4mA input, and 100.00 with 20mA input, but can easily be re-calibrated on-site.

6.1 Summary of programmable functions

This section summarises each of the main programmable functions and includes a cross reference to more detailed information. Fig 6 illustrates the location of each function within the menu.

Display	Description of function
'root'	Square root extractor Turns the square root extractor for linearising the output from differential flowmeters on or off. This function is omitted when a lineariser is installed. See section 6.2
'rESn'	Display resolution Selects the resolution of the least significant display digit. May be set to 1, 2, 5 or 10 digits. See section 6.3
'd.P.'	Decimal point Positions the dummy decimal point between any of the digits or turns it off. See section 6.4
'CAL'	Calibration of display using external current source. Enables the zero and span of the indicator to be adjusted using an external current source such as a calibrator. Also enables a complete loop to be calibrated from primary element to the indicator display. When used with an accurate traceable current source this is the preferred method of calibration. See section 6.5
'SEt'	Calibration of display using internal references. Enables the zero and span of the indicator to be adjusted without the need for an accurate input current or disconnection from the 4/20mA loop. See section 6.6
'Cond'	Indicator conditioning This function provides access to a sub-menu enabling the internal references to be calibrated, and the mains (line) frequency rejection to be selected. Because these parameters will alter the indicator display, they are contained in a sub-menu to prevent inadvertent adjustment. See section 6.7

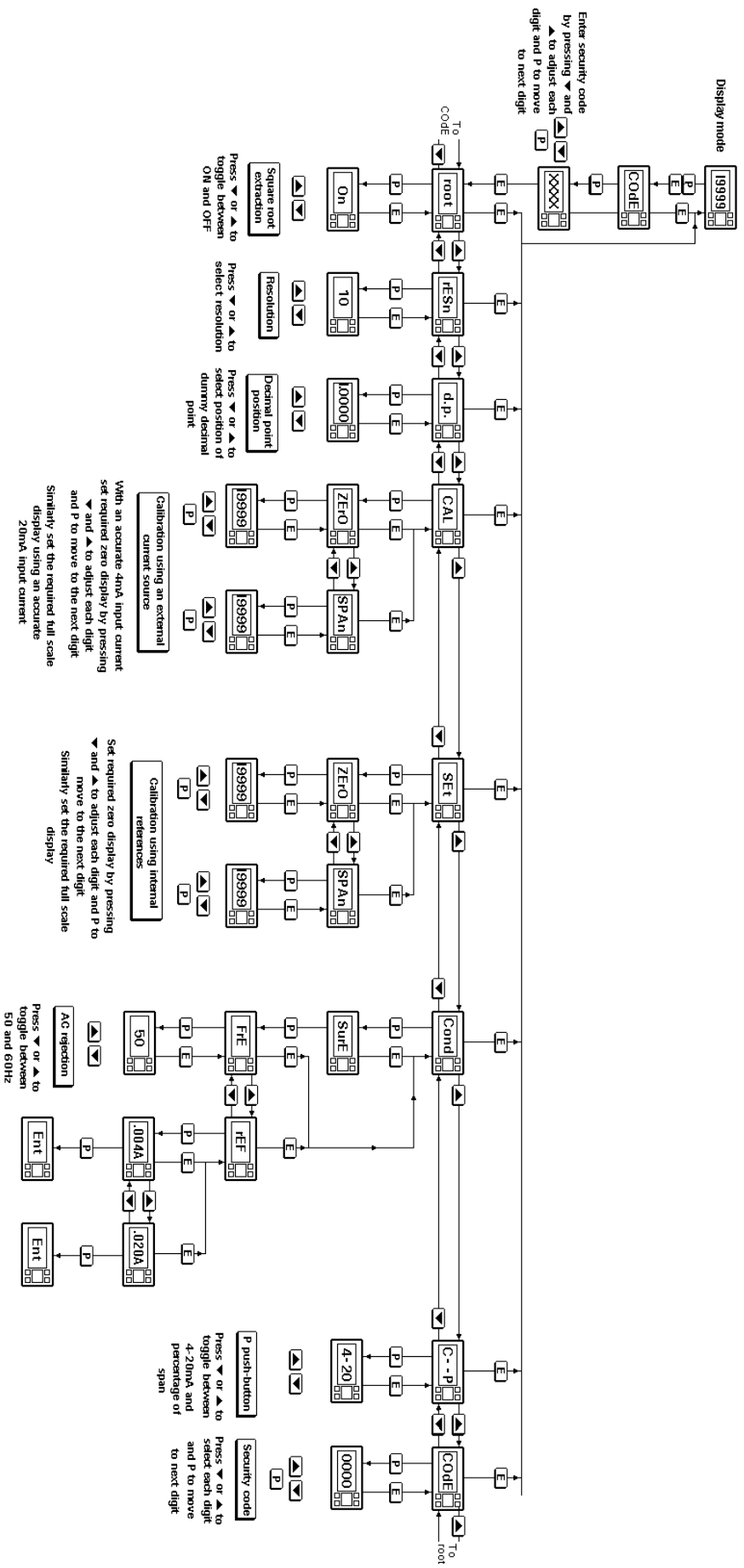

Fig 6 Programming structure

Please read instruction manual before using these functions

Display function	Description of function
'FrE'	<p>Frequency rejection Defines the mains (line) frequency at which the indicator has maximum ac rejection. 50 or 60Hz may be selected. This function must be set before the instrument is calibrated as it affects the indicator display. See section 6.7.1</p>
'rEF'	<p>Calibration of internal references The indicator contains two references representing 4 and 20mA. These internal references are used when the indicator display is calibrated without an external current calibrator, and when the input current is displayed in milliamps. See the SEt and C--P functions. If either of these functions is to be used, the internal references should be periodically calibrated. See section 6.7.2</p>
'C - - P'	<p>Function of P push-button The P push-button may be programmed to display the input current in milliamps or the input current as a percentage of the displayed span. See section 6.8</p>
'COdE'	<p>Security code Defines a four digit numeric code which must be entered to gain access to programmable functions. Default code 0000 disables the security function and allows unrestricted access to all programmable functions. See section 6.9</p>

6.2 Root extractor: root

This function is primarily intended for use with differential flowmeters which have a square law 4/20mA output. To activate the square root extractor select 'root' from the menu and press P which will reveal if the function is 'On' or 'OFF'. If the function is set as required, press E to return to the menu, or press the Up or Down button to change the setting, followed by the E button to return to the main menu.

For reference, the following table shows the output current from a non-linearised differential flowmeter.

% of full flow	Current output mA
2.5	4.01
10.0	4.16
25.0	5.00
50.0	8.00
75.0	13.00
100.0	20.00

6.3 Resolution: rESn

This function defines the resolution of the least significant display digit. Decreasing the display resolution can improve the readability of a noisy signal. Select 'rESn' from the menu and press P which will reveal the current display resolution. To change the resolution press the Up or Down button to select 1, 2, 5 or 10 digits, followed by the E button to return to the menu.

6.4 Position of the decimal point: d.P.

A dummy decimal point can be positioned between any of the digits or may be absent. To position the decimal point select 'd.P.' from the menu and press P. The decimal point can then be moved or turned off by pressing the Up or Down push-button, followed by E to return to the menu.

6.5 Calibration using an external current source: CAL

This function enables the zero and span of the indicator to be adjusted using an external calibrated current source. When used with an accurate traceable current source this is the preferred method of calibration.

To calibrate the indicator select 'CAL' from the main menu and press P. The indicator will display 'ZErO' which is a request for a 4mA input current. Adjust the external current calibrator to 4.000mA and again press P which will reveal the current zero display. Each digit of the indicator display can be changed by pressing the Up or Down buttons. When the first digit is correct pressing P will transfer control to the next digit. When all the digits have been adjusted, press E to enter

the new zero. The indicator will display 'Ent' for a few seconds while the information is being stored in memory, and will then return to the 'ZEro' prompt .

To adjust the display at 20mA, press the *Up* button which will cause the indicator to display 'SPAn'. Adjust the external current calibrator to 20.000mA and again press *P* which will reveal the existing full scale display. Each digit of the indicator display can be changed by pressing the *Up* or *Down* buttons. When the first digit is correct pressing *P* will transfer control to the next digit. When all the digits have been adjusted press *E* to enter the new span. The indicator will display 'Ent' for a few seconds while the information is being stored in memory, and will then return to the 'SPAn' prompt. Finally press *E* again to return to the main menu.

This function may also be used when calibrating a complete loop from primary element to indicator display e.g. when the indicator is displaying the 4/20mA output from a resistance thermometer transmitter.

6.6 Calibration using internal reference: SEt

This function enables the zero and span of the indicator to be adjusted without the need for an accurate external current source, or for disconnection from the 4/20mA loop.

The accuracy of this method depends upon the accuracy of the internal references which should be regularly calibrated as described in section 6.7.2

To calibrate the indicator select 'SEt' from the main menu and press *P*. The indicator will display 'ZEro', pressing *P* again will reveal the current display at 4mA. Each digit of the indicator display can be changed by pressing the *Up* or *Down* buttons. When the first digit is correct pressing *P* will transfer control to the next digit. When the least significant digit has been adjusted, press *E* to return to the 'ZEro' prompt which completes the adjustment.

To adjust the display at 20mA, press the *Up* button which will cause the indicator to display 'SPAn'. pressing *P* again will reveal the indicator display. Each digit can be changed by pressing the *Up* or *Down* buttons. When the first digit is correct pressing *P* will transfer control to the next digit. When the least significant digit has been adjusted press *E* to

return to the 'SPAn' prompt followed by *E* to return to the menu.

6.7 Conditioning sub-menu: Cond

This sub-menu allows the mains (line) frequency at which the indicator has maximum ac rejection to be selected and the two internal references to be calibrated. These functions are contained in a sub-menu to minimise the possibility of inadvertent adjustment. To gain access to the sub-menu select 'Cond' from the main menu and press *P*. The indicator will display 'SurE' to warn that changing the parameters in the sub-menu will change the indicator display. Pressing *P* again will give access to the sub-menu, or pressing *E* will return the indicator to the main menu.

6.7.1 AC rejection: FrE

Caution

If the mains filter frequency is changed, the indicator display and internal references (if used) must be recalibrated.

To provide maximum low frequency rejection the internal digital filter may be set to operate at 50 or 60Hz to correspond with the local mains (line) frequency. To change the frequency select 'FrE' from the Cond sub-menu and press *P* which will reveal the current setting. The setting can be changed by pressing the *Up* or *Down* buttons followed by the *E* button to return to the sub-menu.

6.7.2 Calibration of internal references: rEF

The indicator contains two references representing 4 and 20mA. These references are used in the SEt function which enables the indicator display to be calibrated without an external current calibrator. They are also used in the C--P function when the *P* push-button is programmed to display the input current in the display mode. If neither of these functions is to be used, it is not necessary to calibrate the internal references.

The accuracy of the internal references, and hence the display accuracy, will depend upon the accuracy of the external current source. With a maximum span of 20000 the indicators have a display resolution of 0.8µA, we therefore recommend that the accuracy of the external current source used for calibration is greater than 0.4µA.

To calibrate the references connect a calibrator to terminals 1 and 3. Select 'rEF' from the sub-menu and press *P* which will result in a '0.004A' prompt being displayed. Adjust the external current calibrator to 4.000mA and again press *P*. The indicator will display 'Ent' when the 4mA reference has been updated and will then return to the '.004A' prompt.

To re-calibrate the 20mA internal reference, press the *Up* button which will cause the indicator to display '.020A'. Adjust the external current calibrator to 20.000mA and again press *P*. The indicator will display 'Ent' when the 20mA reference has been updated and will then return to the '.020A' prompt. Two operations of the *E* button will return the indicator to the main menu.

6.8 Function of the *P* push-button: C - - P

This parameter defines the function of the *P* push-button when the indicator is in the display mode. While the button is operated the indicator will display the input current in milliamps, or the input current as a percentage of the span.

To check or change the parameter select 'C - - P' from the main menu and press *P* to reveal the current setting. Pressing the *Up* or *Down* button will toggle the setting between '4-20' the current display and 'PC' the percentage display. When set as required press *E* to return to the main menu.

Accuracy of the current display depends upon the accuracy of the internal references which should be periodically calibrated - see section 6.7.2

6.9 Security code: COdE

The calibration and conditioning of the instrument may be protected by a four digit security code which must be entered before access to the programme menu is granted. New instruments are programmed with the default security code 0000 which allows unrestricted access to all programming functions.

To enter a new security code select 'COdE' from the menu and press *P* which will cause the indicator to display the current security code. Each digit of the code can be changed using the *Up* and *Down* push-buttons, and the *P* button to move to the next digit. When the required code has been entered press *E* to return to the main menu. The revised security code will be activated when the indicator is returned to the operating mode.

If the security code is lost, access to the programmable functions can be obtained by moving the internal security link to the override position. The original security code can then be viewed by selecting 'CodE' from the main menu and pressing *P*.

To gain access to the security code link, remove the instrument terminal block by gently pulling, unscrew the four corner screws securing the rear panel and lift off the panel which will reveal the link as shown in Fig 7.

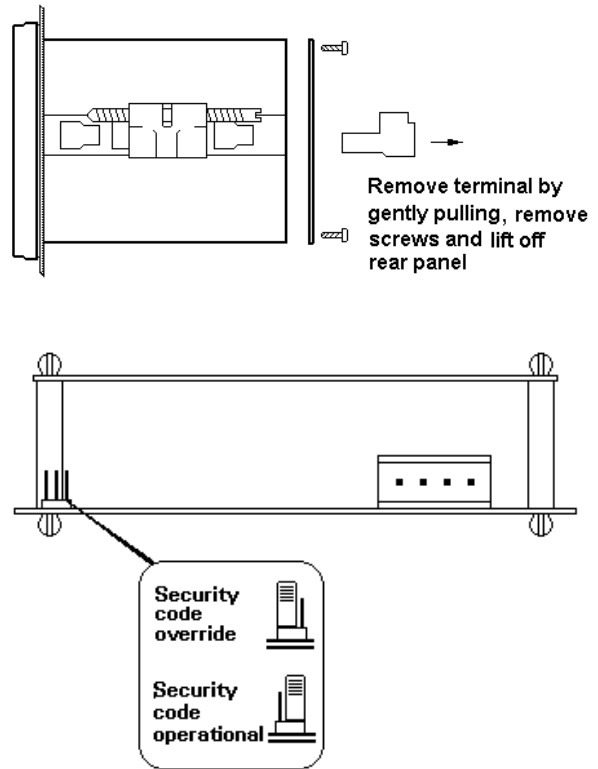

Fig 7 Location of security code override link

6.10 Over and under-range

If the indicator display range is exceeded, the four least significant digits will be blanked. Under-range is indicated by '-1' and over-range by '1'. Under and over-range are also indicated if the input current falls below approximately 3.5mA or rises above approximately 21mA.

If the input current falls below 3mA the instrument initialisation sequence is performed as described in section 2.

7. CALIBRATION EXAMPLES

The following examples illustrate the two ways in which a BA327C or BA328C indicator may be calibrated.

7.1 Using an external calibrator

A BA327C is required to display:

-50.0	with a 4mA input
1050.0	with a 20mA input

from a linear transducer. Maximum display resolution is required, the frequency of the mains supply is 50Hz and the existing security code is 1209. In the operating mode the indicator is required to display the input current as a percentage of span when the *P* push-button is operated.

Step 1 Connect indicator to calibrator

Connect the indicator to an accurate external current source. Terminal 1 positive. The indicator will automatically perform the initialisation routine described in section 2, and then display the input current using the existing calibration information.

Step 2 Enter programming mode

With an input current between 4 and 20mA put the indicator in the programming mode by simultaneously pressing *P* and *E*. The indicator will respond by displaying 'COdE'. Press *P* to clear this prompt and set the display to the security code 1209 using the *Up*, *Down* and *P* push-buttons. Pressing *E* will enter the code, and after a few seconds during which the decimal points will be scrolled, the first parameter 'root' in the main menu will be displayed.

Step 3 Square root extraction

With 'root' displayed, press *P* which will reveal the root extractor status. The root extractor can be turned on or off by the *Up* or *Down* buttons. Select 'OFF', and press *E* to return to the main menu.

Step 4 Select frequency of max rejection

Scroll through the main menu until 'Cond' is displayed. Enter the sub-menu by pressing *P* twice and select the 'FrE' function. Using the *Up* or *Down* buttons select '50', and then press *E* twice to return to the main menu.

Step 5 Define function of *P* push-button

Select 'C--P' from the main menu and press *P* to reveal the function of the *P* button in the display mode. Select percentage 'PC' and return to the main menu by pressing *E*

Note: Because an input current display in milliamps is not required, it is not necessary to calibrate the two internal references.

Step 6 Position dummy decimal point

Scroll through the main menu until 'd.P.' is displayed and then press *P*. Using the *Up* and *Down* push-buttons position the dummy decimal point in front of the least significant digit.

Press *E* to return to the main menu.

Step 7 Calibrate the display

Scroll through the main menu until 'CAL' is displayed. Press *P* and the indicator will request a 4mA input by displaying 'ZEro'. Set the input current to $4.0000 \pm 0.0004\text{mA}$ and press *P* again which will reveal the existing zero display. Using the *Up*, *Down* and *P* push-buttons enter the required zero display of -50.0 Press *E* to return to the 'ZEro' prompt.

Press the *Up* push-button and the indicator will request a 20mA input by displaying 'SPAN'. Set the input current to $20.0000 \pm 0.0004\text{mA}$ and again press *P* which will reveal the existing span display. Using the *Up*, *Down* and *P* push-buttons enter the required display of 1050.0

Press *E* twice to return to the main menu.

Step 8 Return to the display mode

Return to the display mode by pressing *E*.

7.2 Using the internal calibrator

As in 7.1 the BA327C is required to display:

-50.0	with a 4mA input
1050.0	with a 20mA input

from a linear transducer. Maximum display resolution is required, the frequency of the

mains supply is 50Hz and the existing security code is 1209. In the operating mode the indicator is required to display the input current in milliamps when the *P* push-button is operated.

This example assumes that the internal references have been routinely calibrated.

Step 1 Enter the programming mode

With an input current between 4 and 20mA put the indicator in the programming mode by simultaneously pressing *P* and *E*. The indicator will respond by displaying 'COdE'. Press *P* to clear this prompt and set the display to the security code 1209 using the *Up*, *Down* and *P* push-buttons. Pressing *E* will enter the code, and after a few seconds during which the decimal points will be scrolled, the first parameter 'root' in the main menu will be displayed.

Step 2 Square root extractor

With 'root' displayed, press *P* which will reveal the root extractor status. The root extractor can be turned on or off by the *Up* or *Down* buttons. Select 'OFF', and press *E* to return to the main menu.

Step 3 Select frequency of max rejection

Scroll through the main menu until 'Cond' is displayed. Enter the sub-menu by pressing *P* twice and select the 'FrE' function. Using the *Up* or *Down* buttons select '50', and then press *E* twice to return to the main menu.

Step 4 Define function of *P* push-button

Select 'C--P' from the main menu and press *P* to reveal the function of the *P* button in the display mode. Select '4-20' and return to the main menu by pressing *E*.

Step 5 Position dummy decimal point

Select 'd.P' from the main menu and then press *P*. Using the *Up* and *Down* push-buttons position the dummy decimal point in front of the least significant digit. Press *E* to return to the main menu.

Step 6 Calibrate display

With any input current between 4 and 20mA select 'SEt' from the main menu and press *P*. The indicator will display 'ZEro' in the sub-menu, press *P* to reveal the existing zero display. Using the *Up*, *Down* and *P* push-buttons enter the required zero display of -50.0 Press *E* to return to the 'ZEro' prompt.

With any input current between 4 and 20mA press the *Up* push-button and the indicator will display 'SPAN'. Press *P* to reveal the existing span display. Using the *Up*, *Down* and *P* push-buttons enter the required span display of 1050.0 Press *E* to return to the 'SPAN' prompt. Press *E* again to return to the main menu.

Step 7 Return to display mode

Return to the display mode by pressing '*E*'.

8. MAINTENANCE

8.1 Fault finding during commissioning

If a BA327C or BA328C fails to function during commissioning the following procedure should be followed:

Symptom	Cause	Solution
No display	Incorrect Wiring.	There should be 1V between terminals 1 & 3 with terminal 1 positive.
No display, 0V between terminals 1 and 3.	Incorrect wiring or no power supply.	Check that a current is flowing in the loop.
	Insufficient loop voltage to operate indicator.	Check supply voltage and voltage drops caused by all components in the loop.
Indicator displays 1 incorrectly	Positive	The indicator has been over-range. been calibrated & is trying to display a number greater than 19999.
		The indicator has been incorrectly calibrated & is trying to display a number less than -19999.
Indicator displays -1	Negative over-range.	The indicator has been incorrectly calibrated & is trying to display a number less than -19999.
Unstable loop supply display	has a large ripple content.	4/20mA input Check voltage.
Unable to enter the or fit security programme mode.	Incorrect code entered.	Enter correct security code
		link in override position. See Fig 7.

8.2 Fault finding after commissioning

ENSURE PLANT SAFETY BEFORE STARTING MAINTENANCE

Live maintenance is permitted on intrinsically safe equipment installed in a hazardous area, but only certified test equipment should be used unless a gas clearance certificate is available.

If a BA327C or BA328C fails after it has been functioning correctly, the following procedure should be followed:

Symptom	Cause	Solution
No display, 0V between terminals 1 and 3.	No power supply	Check that current is flowing in the loop.
Unstable loop supply display	has a large ripple.	4/20mA input Check voltage.
		Digital filter
Incorrect calibration	Recalibrate	
	FrE has been changed after indicator was calibrated.	

If this procedure does not reveal the cause of the fault, it is recommended that the instrument is replaced. This can be done without disconnecting power, but while the indicator is disconnected the 4/20mA loop will be open circuit.

8.3 Servicing

All standard BA327C and BA328C indicators are interchangeable, a single spare assembly may therefore be used to replace any instrument which fails.

We recommend that faulty instruments and instrument assemblies are returned to BEKA associates or to your local BEKA agent for repair.

8.4 Routine maintenance

The mechanical condition of the instrument and electrical calibration should be regularly checked. The interval between inspections depends upon environmental conditions. We recommend that initially instrument calibration should be checked annually.

8.5 Guarantee

Indicators which fail within the guarantee period should be returned to BEKA associates or our local agent. It is helpful if a brief description of the fault symptoms is provided.

8.6 Customer comments

BEKA associates is always pleased to receive comments from customers about our products and services. All communications are acknowledged and whenever possible, suggestions are implemented.

9. ACCESSORIES

9.1 Scale card

The BA327C and the BA328C have a window on the right hand side of the display to hold a card showing the units of measurement e.g. °C, mBar, RPM. Indicators can be supplied with a printed scale card showing any units specified at the time of ordering. If a printed scale card is not requested, a blank card will be supplied.

Scale cards can easily be marked on site as follows:

- a. Remove the rear terminal block and the rear panel as shown in Fig 7.
- b. Carefully pull the indicator assembly from the enclosure.
- c. Gently pull and then slide the blank scale card towards the display window until it is free. Mark the card with the required legend and replace in the slot.

9.2 Tag strip

Instruments can be supplied with a thermally printed tag number on the rear panel. This tag number is not visible from the front of the instrument after installation.

9.3 Alarms

The BA327C and the BA328C can be supplied with two solid state single pole alarm outputs which may be independently programmed as high or low alarms with normally open or normally closed outputs. Fig 8 illustrates the conditions available and shows which are fail safe, i.e. output is in the alarm condition (open) when the 4/20mA input current is zero.

WARNING

These alarms outputs should not be used for critical safety applications such as an emergency shut down system.

When an alarm is activated the indicator display alternates between the measured value and an alarm identification.

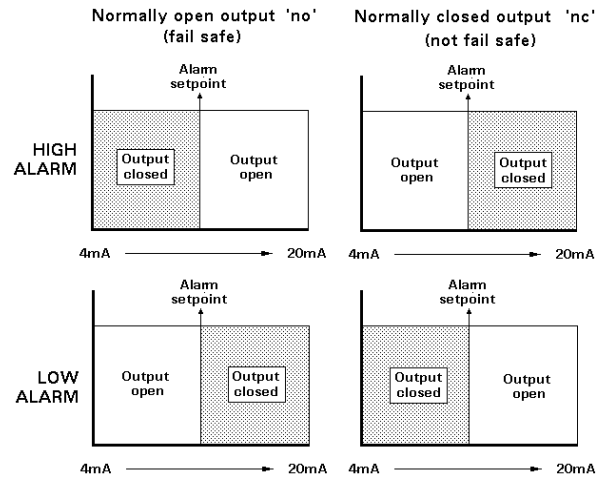

Fig 8 Alarm outputs

Programmable functions for each alarm include adjustable setpoint, hysteresis, alarm delay and alarm accept.

9.3.1 Solid state output

Each alarm has a galvanically isolated single pole solid state switch output which is shown in Fig 9. The output is polarised and current will only flow in one direction.

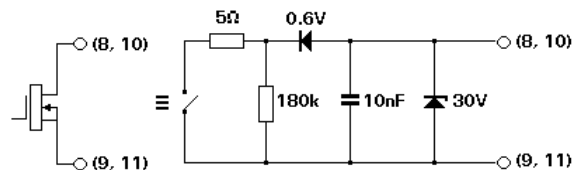

Fig 9 Equivalent circuit of each alarm output

9.3.2 Intrinsic safety

Each alarm output is a separate galvanically isolated solid state switch which has been certified as *simple apparatus*. This allows the alarm terminals 8 & 9 and 10 & 11 to be connected to any intrinsically safe circuit protected by a Zener barrier or galvanic isolator providing the output parameters of the circuit do not exceed:

$$\begin{aligned}
 U_o &= 28V \text{ dc} \\
 I_o &= 200\text{mA} \\
 P_o &= 0.85W
 \end{aligned}$$

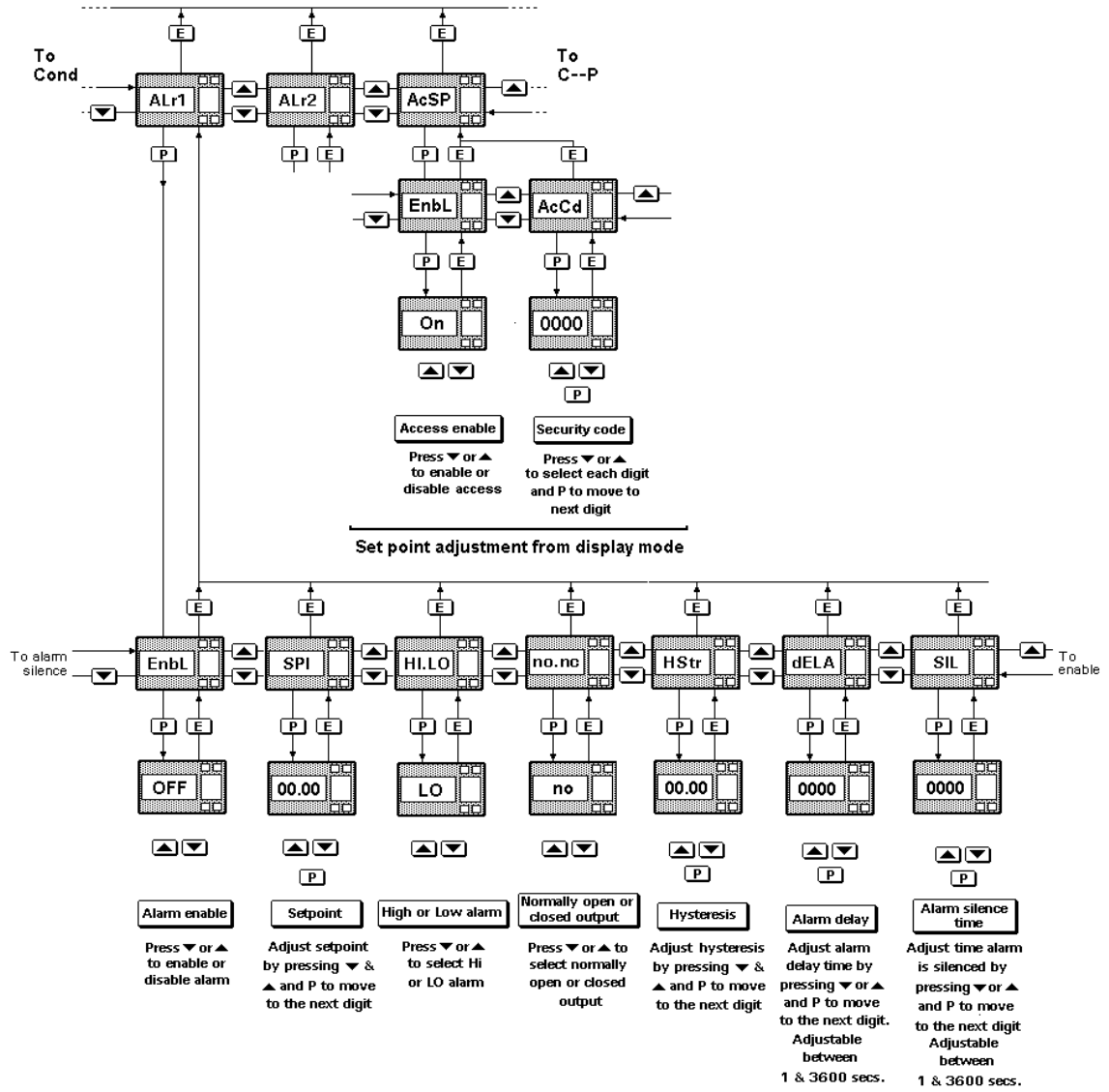

Fig 10 Programme structure of optional alarms

The maximum equivalent capacitance and inductance between each set of alarm terminals is:

$$C_i = 20\text{nF}$$

$$L_i = 10\mu\text{H}$$

These figures must be subtracted from the maximum permitted cable capacitance and inductance specified by the system certificate of the circuit connected to the alarm.

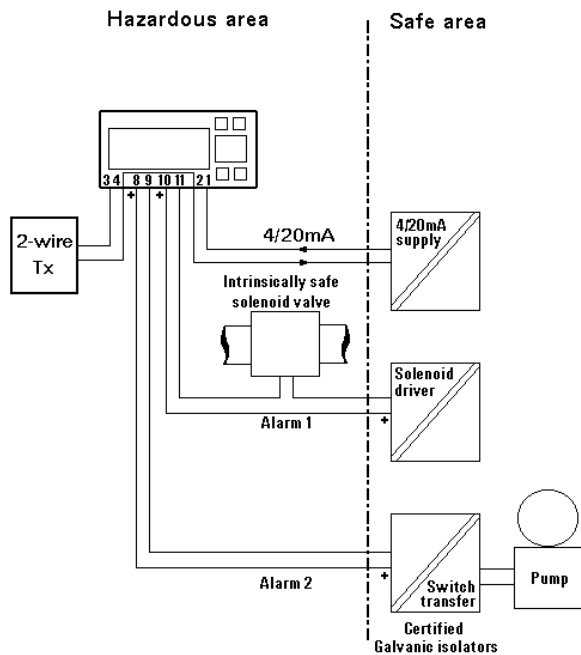

Fig 11 Typical alarm application

9.3.3 Programming and adjustment

When an alarm card is added to a BA327C or BA328C indicator the main programme menu is extended as shown in Fig 10. The additional functions appear between Cond and C--P in the main menu. For simplicity Fig 10 only shows the additional functions available on alarm 1, but alarm 2 has identical facilities.

The following table summaries each of the alarm programme functions and includes a cross reference to more detailed information. Again only the functions on alarm 1 are listed, but alarm 2 has identical facilities

Summary of programmable alarm functions

Display	Description of function
---------	-------------------------

- | | |
|----------------|--|
| 'EnbL' | Alarm enable
Enables or disables the alarm function without changing the alarm parameters.
See section 9.3.4 |
| 'SP1' | Alarm setpoint 1
Adjusts the alarm setpoint. The alarm is activated when the indicator display equals the setpoint.
See section 9.3.5 |
| 'HI.LO' | Alarm function
Defines whether the alarm has a high or low function
See section 9.3.6 |
| 'no.nc' | Normally open or normally closed output
Determines whether the single pole alarm output is open or closed in the alarm condition.
See section 9.3.7 |
| 'HStr' | Hysteresis
Adjusts the alarm hysteresis.
See section 9.3.8 |
| 'dELA' | Alarm delay time
Adjusts the delay between the display equalling the setpoint and the alarm output being activated.
See section 9.3.9 |
| 'SIL' | Alarm silence time
Defines the time that the alarm output remains in the non-alarm condition following acceptance of an alarm.
See section 9.3.10 |
| 'AcSP' | Access setpoint
Sub-menu which enables direct access to the alarm setpoints from the indicator display mode, and defines a separate security code.
See section 9.3.11 |

9.3.4 Alarm enable: EnbL

This function allows the alarm to be enabled or disabled without altering any of the alarm parameters. To check or change the function select 'EnbL' from the alarm menu and press *P* which will reveal the current setting. The function can be changed by pressing the *Up* or *Down* button followed by the *E* button to return to the alarm menu.

9.3.5 Setpoint adjustment: SP1 and SP2

The setpoint of each alarm may be positioned anywhere between -19999 and 19999 providing this corresponds to an input current between 3.8 and 20.2mA. e.g. If the indicator has been calibrated to display 0 with 4mA input and 10000 with 20mA input, the two alarm setpoints may be positioned anywhere between -125 and 10125.

To adjust the setpoint select 'SP1' or 'SP2' from the alarm menu and press *P* which will reveal the existing alarm setpoint. Each digit of the setpoint can be adjusted using the *Up* and *Down* push-buttons, and the *P* button to move to the next digit. When the required setpoint has been entered press *E* to return to the alarm menu.

9.3.6 Alarm function: HI.LO

Each alarm can be conditioned as a high or low alarm. To check or change the alarm function select 'HI.LO' from the alarm menu and press *P* to reveal the current setting. The function can be changed by pressing the *Up* or *Down* buttons followed by the *E* button to return to the alarm menu.

9.3.7 Alarm output status: no.nc

This function allows the alarm output to be open or to be closed in the alarm condition. When deciding which is required, care must be taken to ensure that the alarm output is fail safe. See Fig 8.

WARNING

When the 4/20mA supply is removed both alarm outputs will open irrespective of conditioning. Therefore for fail safe operation both alarm outputs should be programmed to be open in the alarm condition.

To check or change the alarm output status select 'no.nc' from the alarm menu and press *P* reveal the current setting. The function can be changed by pressing the *Up* or *Down* button followed by the *E* button to return to the alarm menu.

9.3.8 Hysteresis: HStr

During programming hysteresis is shown in the units the indicator has been calibrated to display.

To adjust the hysteresis select 'HStr' from the alarm menu and press *P* which will reveal the existing figure. Each digit can be adjusted using the *Up* and *Down* push-buttons, and the *P* button to move to the next digit. When the required hysteresis has been entered press *E* to return to the alarm menu.

e.g. An indicator calibrated to display 0 to 10000, with a high alarm set at 9000 and hysteresis of 200 will perform as follows:

High alarm will be activated when display equals or exceeds 9000, but will not reset until the display falls below 8800.

9.3.9 Alarm delay: dELA

This function enables activation of the alarm output to be delayed for a fixed time following the alarm condition occurring. The delay can be programmed in 1 second increments up to 3600 seconds. If a delay is not required zero should be entered. To adjust the delay select 'dELA' from the alarm menu and press *P* which will reveal the existing delay. Each digit of the delay can be adjusted using the *Up* and *Down* push-buttons, and the *P* button to move to the next digit. When the required delay has been entered press *E* to return to the alarm menu.

9.3.10 Alarm silence time: SIL

This function is primarily intended for use in small installations where the alarm output directly operates an annunciator such as a sounder. When the alarm silence time is set to any figure other than zero, the *P* push-button becomes an alarm accept button. After an alarm has occurred, operating the *P* button will cause the alarm output to revert to the non-alarm condition for the programmed alarm silence time. The display will continue to indicate an alarm after it has been accepted and silenced. The alarm silence time may be adjusted between 0 and 3600 seconds in 1 second increments.

To adjust the alarm silence time select 'SIL' from the alarm menu and press *P* which will reveal the existing time. Each digit can be adjusted using the *Up* and *Down* push-buttons, and the *P* button to move to the next digit. When the required time has been entered press *E* to return to the alarm menu.

9.3.11 Access Setpoint: AcSP

This function controls a separate menu which provides direct access to the alarm setpoints when the indicator is in the display mode. See section 9.3.12 for a full description. An operator may therefore adjust the alarm setpoints without having access to the programme and alarm menus. Further protection is provided by a separate security code.

This direct access menu is enabled and a separate security code entered from the 'AcSP' function in the programme menu as shown in Fig 11. To change the menu parameters select 'AcSP' from the programme menu and press *P* which will display the enable prompt 'EnbL'. Press *P* again to reveal if the direct access menu is 'On' or 'OFF'. The *Up* or *Down* buttons will toggle the display between the two conditions.

If 'OFF' is selected, the operator will not have access to the setpoints from the display mode. Return to the 'AcSP' prompt in the main menu by pressing *E* twice.

If 'On' is selected, the operator will have direct access to the alarm setpoints from the display mode via a separate optional security code. To define the four digit numerical code press *P* to return to the 'EnbL' prompt followed by the *Up* or *Down* button to select the access code prompt 'AcCd'. Pressing *P* will reveal the current security code. Each digit of the code may be changed by operating the *Up* and *Down* push-buttons, and the *P* button to move to the next digit. When the required code has been entered, press *E* twice to return to the 'AcSP' prompt in the Programme Menu.

Code 0000 will disable the security code allowing direct access to the setpoints by pressing the *P* and *Up* buttons simultaneously. New instruments with alarms are supplied with this function disabled and the security code set to 0000

9.3.12 Adjusting alarm setpoints from the display mode

Access to the alarm setpoints from the indicator display mode is obtained by operating the *P* and *Up* push-buttons simultaneously as shown in Fig 12. If the setpoints are not protected by a security code the alarm setpoint prompt 'SP1' will be displayed. If the setpoints are protected by a security code, 'COde' will be displayed first. Pressing *P* again will enable the alarm security code to be entered digit by digit using the *Up* and *Down* buttons to change the flashing digit,

and the *P* push-button to move to the next digit. If the

correct code is entered pressing *E* will cause alarm setpoint prompt 'SP1' to be displayed. Pressing the *Up* or *Down* button will toggle the display between the two alarm setpoint prompts 'SP1' and 'SP2'.

If an incorrect security code is entered, or a button is not pressed within ten seconds, the indicator will automatically return to the display mode.

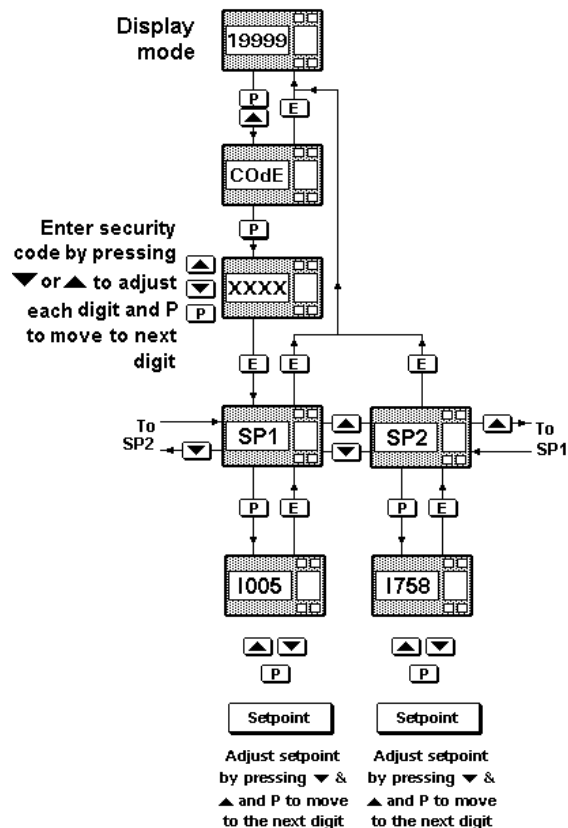

Fig 12 Setpoint adjustment from the display mode

To adjust an alarm setpoint select 'SP1' or 'SP2' and press *P* which will reveal the current setting. Each digit of the setpoint may be adjusted using the *Up* and *Down* push-buttons, and the *P* button to move to the next digit. When the required setpoint has been entered, pressing *E* will return the display to the 'SP1' or 'SP2' prompt from which the other setpoint may be selected, or the indicator may be returned to the display mode by pressing *E* again.

Direct access to the alarm setpoints is only available when the menu is enabled - see section 9.3.11

9.4 Lineariser

The indicator can be supplied with a sixteen point lineariser which may be adjusted to compensate for almost any non linear variable. For example, a level signal from a horizontal cylindrical tank may be linearised by the indicator to display the tank contents in linear volumetric units.

The addition of linearising software does not affect the intrinsic safety of the indicator.

Fig 13 shows a typical linearising characteristic. Up to sixteen break-points may be programmed to occur at any input current between 4 and 20mA. The slope between adjacent break-points may be set anywhere between -1250 and +1250 display counts per milliamp. Greater slopes may be programmed, but the indicator performance will be degraded. A linear characteristic can be obtained by programming just two points, one at 4mA and the other at 20mA.

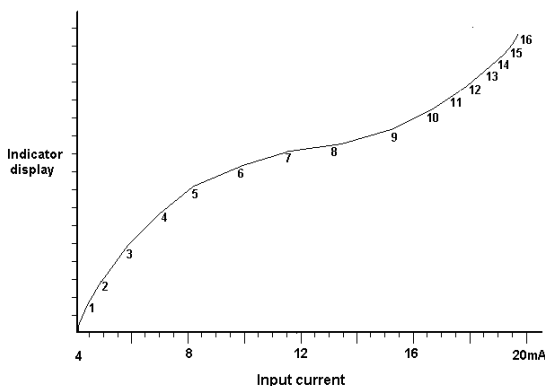

Fig 13 Typical indicator characteristic

The lineariser software does not change the main programme menu, but the CAL and SET functions are extended as shown in Fig 14. As with a linear indicator, calibration may be performed with an external calibrator using the 'CAL' function, or from the internal references using the 'Set' function.

9.4.1 Calibration using an external source

This method allows direct calibration with a current source, and is preferred when traceability is required. If the exact system non-linearity is unknown, the method also allows direct calibration from the variable to be displayed. e.g. the output from a level sensor in an irregular tank may be displayed in linear volumetric units by filling the tank with known incremental volumes and calibrating the indicator to display the sum of the increments at each break-point.

The number of break-points required should first be entered using the Add and dEL functions. In both these functions the indicator initially displays the current break-point and the total number of break-points being used. e.g.

5	13
current break-point	total number of break-points

'Add' **Add a break-point**
Adds a new break-point before the displayed break-point. The calibration of existing break-points is not changed, but the identification number of all subsequent break-points is increased by one.

'dEL' **'Remove a break-point**
Removes the displayed break-point and joins the preceding break-point to the following break-point with a straight line. The identification number of all subsequent break-points is decreased by one.

To add a break-point select 'CAL' from the main menu and press *P* to enter the 'Add' function; press *P* again to reveal the current and total number of break-points. Each subsequent operation of the *P* push-button will introduce an additional break-point. When adding a break-point to a calibrated indicator, the insertion position can be selected using the *Up* and *Down* push-buttons.

The delete break-point function dEL operates in a similar manner to the Add function described above.

When the required number of break-points has been entered, return to the sub-menu by pressing *E*. The indicator will display 'Add' or 'dEL' depending upon the last function used. Each break-point can now be programmed

Select 'PtS' from the sub-menu and press *P* which will select the first break-point '0 n', where n is the total number of break-points entered. The selected break-point can be changed using the *Up* and *Down* buttons. When the required break-point has been selected press *P*. Set the indicator input current to the exact value at which the break-point is to occur, and adjust the indicator display using the *Up* and *Down* buttons and *P* to move between digits. When the required display has been set, press *E* to enter

the information and return to the sub-menu from which another break-point can be selected.

Repeat this procedure for each break-point, and then return to the main menu by pressing *E* twice.

9.4.2 Calibration using internal references

This function enables the break-points to be adjusted without the need for an accurate external current source. Throughout calibration the indicator input current may be any value between 4 and 20mA.

The accuracy of this method depends upon the accuracy of the internal references which should be calibrated periodically against a traceable external current source with a resolution of at least 0.4µA. See section 6.7.2

The number of break-points required should first be entered using the Add and dEL functions. In both these functions the indicator initially displays the current break-point and the total number of break-points being used. e.g.

5	13
current break-point	total number of break-points

- 'Add'** **Add a break-point**
Adds a new break-point before the displayed break-point. The calibration of existing break-points is not changed, but the identification number of subsequent break-points is incremented.
- 'dEL'** **Remove a break-point**
Removes the displayed break-point and joins the preceding break-point to the following break-point with a straight line. The identification number of all of subsequent break-points is decremented.
- 'inPut'** **Defines the current at which break-point occurs**
Enables the required current at each break-point to be defined without having to input an accurate current to the indicator.
- 'diSP'** **Defines display at break-point**

Enables the indicator display at each break-point to be defined.

Select 'SEt' from the main menu and press *P* once to enter the 'Add' function, and again to reveal the current and total number of break-points. Each subsequent operation of the *P* push-button will introduce an additional break-point. When adding a break-point to a calibrated indicator, the insertion position can be selected using the *Up* and *Down* push-buttons.

The delete break-point function dEL operates in a similar manner to the Add function described above.

When the required number of break-points has been entered, return to the sub-menu by pressing *E*. The indicator will display 'Add' or 'dEL' depending upon the last function used. The required indicator display at each break-point can now be entered, followed by the input current at which each break-point occurs.

To enter the required display at any break-point select 'diSP' from the sub-menu and press *P* which will select the first break-point '0 n'. The selected break-point can be changed using the *Up* and *Down* buttons. When the required break-point has been selected press *P* to reveal the existing display. Use the *Up* and *Down* buttons and *P* to move between digits set the revised display. Press *E* to return to the sub-menu from which another break-point can be selected. Repeat this procedure for all the break-point displays to be changed, and then return to the 'diSP' prompt in the sub-menu by pressing *E*.

To enter the input current at which each break-point occurs select 'InPut' from the sub-menu and press *P* which will select the first break-point '0 n'. The selected break-point can be changed using the *Up* and *Down* buttons. When the required break-point has been selected press *P* to reveal the input current at which the break-point occurs. Using the *Up* and *Down* buttons and *P* to move between digits set the revised input current. Press *E* to return to the sub-menu from which another break-point can be selected.

Repeat this procedure for all the break-point input currents to be changed, and then return to the 'InPut' prompt in the sub-menu by pressing *E*.

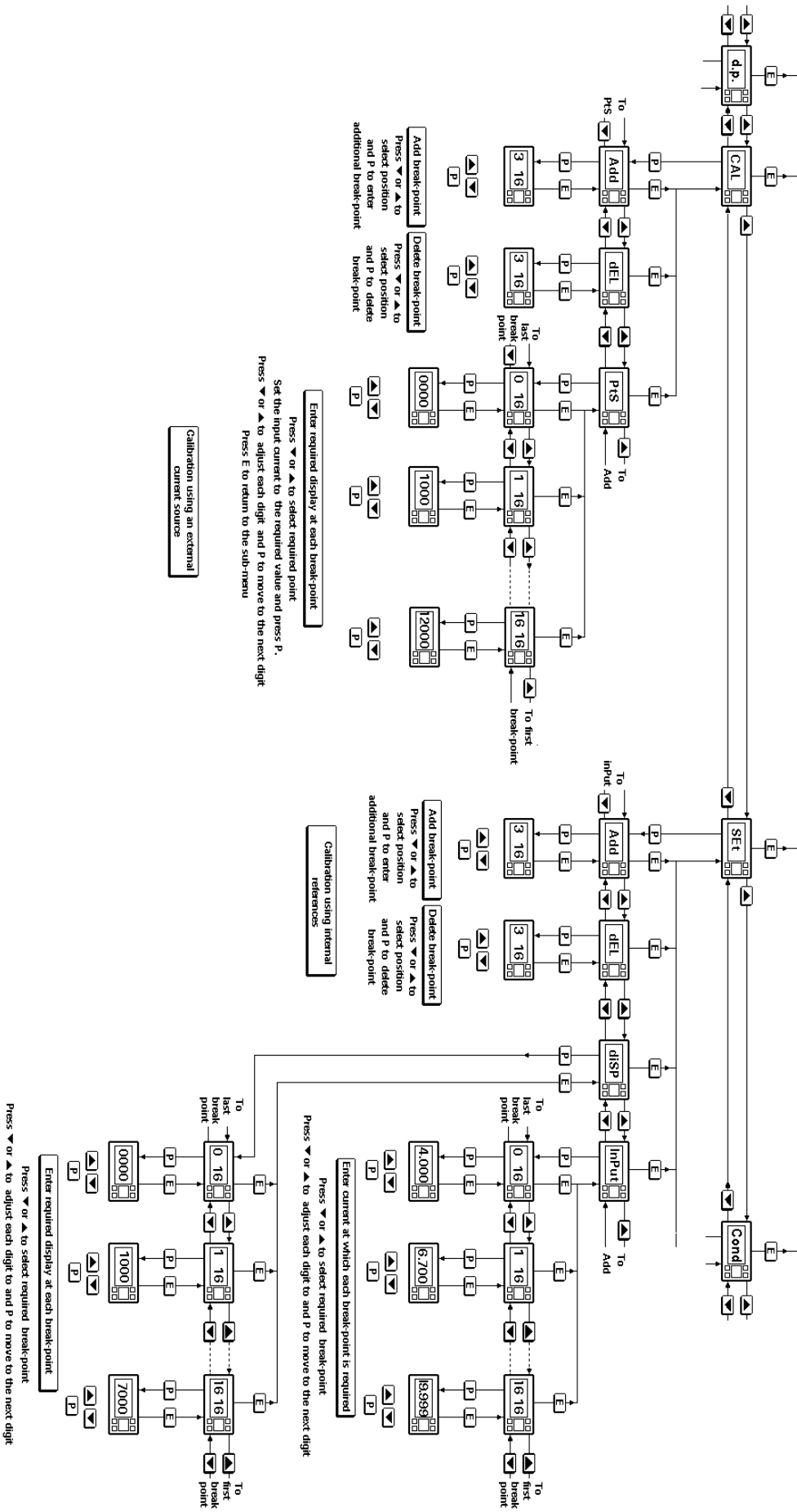

Fig 14 Lineariser programme menu

9.5 Tare function

The tare function is a factory fitted software accessory, primarily intended for use with weighing systems.

When the tare software is installed, pushing and holding the *P* button for more than approximately 3 seconds sets the indicator display to zero, irrespective of the input current, and activates the tare annunciator on the indicator display. Subsequent operation of the *P* push-button for less than 3 seconds will toggle the indicator between the normal gross display and the net display with the tare annunciator activated.

The tare function allows an operator to quickly zero the indicator display at any input current so that subsequent readings only show the change in input since the *P* push-button was operated. When used with a weighing system, it allows the weight of a container to be automatically subtracted from the total gross weight so that only the net weight of the contents is displayed.

9.6 Display backlights

The BA327C and BA328C can be supplied with one of two different backlights. The loop powered backlight produces green background illumination enabling the display to read at night or in poor lighting conditions. No additional power supply, IS interface or field wiring are required, but the indicator voltage drop is increased. Alternatively, the separately powered backlight has a bright orange output which enhances daylight viewing, but an additional IS interface and field wiring are required.

9.6.1 Separately powered backlight

The separately powered backlight is segregated from the measuring circuit and has been certified as a separate intrinsically safe circuit, but it does not comply with the requirements for simple apparatus.

This backlight must be powered from the safe area via a Zener barrier or a galvanic isolator as shown in Fig 15. Any certified device may be used, providing the output parameters do not exceed:

$$\begin{aligned} U_o &= 28V \text{ dc} \\ I_o &= 110mA \\ P_o &= 0.77W \end{aligned}$$

For guidance, System Certificates ITS No Ex02E2029 and 2030 have been issued

which list some of the devices that may be used.

The EC-Type Examination Certificate specifies that the maximum equivalent capacitance and inductance between terminals 12 and 13 is:

$$\begin{aligned} C_i &= 0.045\mu F \\ L_i &= 0.02mH \end{aligned}$$

To determine the maximum permitted cable parameters, these figures should be subtracted from the maximum permitted cable capacitance and inductance specified by the certificate for the Zener barrier or galvanic isolator powering the backlight.

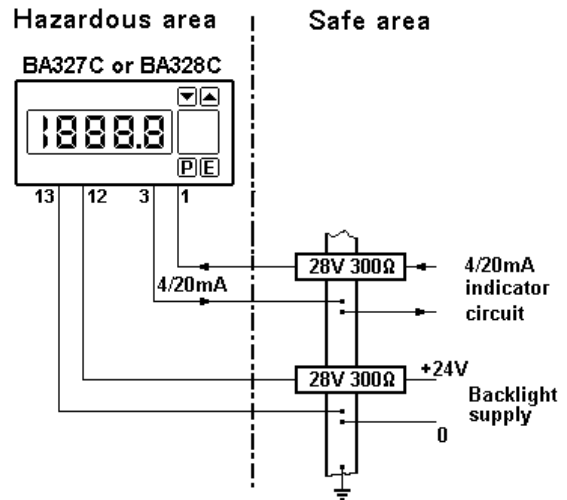

Fig 15 Separately powered backlight

The display brilliance depends upon the current flowing through the backlight. This is determined by the supply voltage and the end-to-end resistance of the Zener barrier or output resistance of the galvanic isolator. Brilliance will not be significantly reduced until the current falls below 20mA.

The BA327C backlight requires a minimum supply voltage of 14V and the larger BA328C backlight a minimum supply voltage of 18V. The backlight current can be calculated from:

For a BA327C

$$\text{Backlight mA} = \frac{V_{\text{supply}} - 14}{\text{End-to-end resistance of barrier\#}}$$

For a BA328C

$$\text{Backlight mA} = \frac{V_{\text{supply}} - 18}{\text{End-to-end resistance of barrier\#}}$$

or output resistance of galvanic isolator

Connecting the backlight in series with the indicator will increase the total voltage drop in the 4/20mA measuring loop from 1.1V to 5.0V

Two indicator backlights may be powered in parallel from a single 28V 300 Zener barrier or galvanic isolator, but the display brilliance will be reduced.

9.6.2 Loop powered backlight

This backlight may be connected in series with the 4/20mA measuring circuit so that, like the indicator, it is loop powered. This eliminates the need for a separate Zener barrier or galvanic isolator and associated wiring for the backlight, thus significantly reducing the installation cost.

As shown in Fig 16 the backlight is connected in series with the indicator. Any Zener barrier or galvanic isolator certified EEx ia IIC by an EEC approved certification body may be used providing output parameters do not exceed:

- Uo = 30V dc
- Io = 200mA
- Po = 0.85W

For guidance, System Certificates ITS No Ex02E2031 and 2032 have been issued which list some of the devices that may be used.

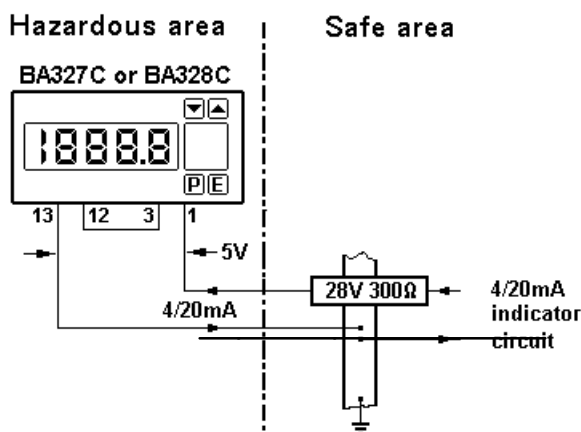

Fig 16 Loop powered backlight

Appendix 1 Installation in USA

A1.0 Factory Mutual Approval

For installations in the USA both indicators and all accessories have been approved by Factory Mutual as intrinsically safe for Class I, Divisions 1 and 2; and nonincendive for Class I, Division 2.

Installations must comply with the BEKA associates control drawing CI320-22, ANSI/ISA RP12.6 and the National Electrical Code ANSI/NFPA70.

A1.1 4/20mA input in intrinsically safe circuit

The BA327C and BA328C have been evaluated under the entity concept, and may be connected in series with any intrinsically safe circuit having output parameters equal to or less than:

$$\begin{aligned} V_{oc}, V_t &= 32V \\ I_{sc}, I_t &= 200mA \end{aligned}$$

The 4/20mA input terminals have a maximum equivalent capacitance and inductance of:

$$\begin{aligned} C_i &= 0.02\mu F \\ L_i &= 0.01mH \end{aligned}$$

These figures must be subtracted from the maximum permissible cable capacitance and inductance allowed for the Zener barrier or galvanic isolator powering the loop into which the indicator is installed.

See Figs 2 and 3.

A1.2 4/20mA input in nonincendive circuit

The BA327C and BA328C are also Factory Mutual approved as nonincendive for Class I, Division 2 locations, which allows both indicators to be installed in Division 2 without the need for Zener barriers or galvanic isolators. The maximum supply voltage must be less than 32V, and the wiring must be nonincendive or 'Division 2 suitable' as defined in the National Electrical Code ANSI/NFPA70.

A1.3 Accessories

The Factory Mutual approval includes the Alarms, Lineariser, Tare function and Display backlight accessories. Only the alarms and backlight have external connections which affect installation.

A1.3.1 Alarms

The FM approval allows the BA327C and BA328C to be fitted with an alarm card which contains two totally independent alarms each with a single pole solid state output.

A1.3.1.1 intrinsic safety

Each alarm has a galvanically isolated single pole output which may be connected to any intrinsically safe circuit having entity output parameters equal to or less than:

$$\begin{aligned} V_{oc}, V_t &= 32V \\ I_{sc}, I_t &= 159mA \end{aligned}$$

Each of the alarm outputs has a maximum equivalent capacitance and inductance of:

$$\begin{aligned} C_i &= 0.04\mu F \\ L_i &= 0.02mH \end{aligned}$$

These figures must be subtracted from the maximum permissible cable capacitance and inductance allowed for the Zener barrier or galvanic isolator connected to the alarm output.

See Figs 8, 9 and 10.

A1.3.1.2 Nonincendive applications

For nonincendive applications a Zener barrier or galvanic isolator is not required. Each alarm output may switch any dc circuit providing the voltage does not exceed 32V and the current is less than 250mA. The wiring must be nonincendive or 'Division 2 suitable' as defined in the National Electrical Code ANSI/NFPA70.

A1.3.2 Display backlight

Either the separately powered or the loop powered backlight may be used.

A1.3.2.1 Separately powered backlight

The backlight is segregated from the measuring circuit and has been approved as a separate intrinsically safe circuit under the entity concept. The backlight may be powered from any certified associated apparatus such as a Zener barrier or galvanic isolator having output parameters equal to or less than:

$$\begin{aligned} V_{oc}, V_t &= 32V \\ I_{sc}, I_t &= 159mA \end{aligned}$$

The backlight terminals have a maximum equivalent capacitance and inductance of:

$$\begin{aligned} C_i &= 0.03\mu F \\ L_i &= 0.01mH \end{aligned}$$

These figures must be subtracted from the maximum permissible cable capacitance and inductance allowed for the Zener barrier or galvanic isolator powering the backlight.

Segregation between the backlight and the measuring circuits should be maintained by following the wiring methods recommended in ANSI/NFPA70 article 504.

See Fig 15.

A1.3.2.2 Loop powered backlight

This backlight has been approved as a separate intrinsically safe circuit under the entity concept. As shown in Fig 16 the backlight may be connected in series with the indicator and powered from any certified associated apparatus such as a Zener barrier or galvanic isolator having output parameters equal to or less than:

$$\begin{aligned} V_{oc}, V_t &= 32V \\ I_{sc}, I_t &= 200mA \end{aligned}$$

The backlight and indicator terminals have a maximum equivalent capacitance and inductance of:

$$\begin{aligned} C_i &= 0.05\mu F \\ L_i &= 0.02mH \end{aligned}$$

These figures must be subtracted from the maximum permissible cable capacitance and inductance allowed for the Zener barrier or galvanic isolator powering the backlight.

A1.3.2.3 Nonincendive applications

For nonincendive applications the separately powered backlight may be connected to a dc supply between 18 and 30V without the need for a Zener barrier or galvanic isolator. The wiring must be nonincendive or 'Division 2 suitable' as defined in the National Electrical Code ANSI/NFPA70.

Similarly the loop powered backlight may be connected in series with the 4/20mA measurement loop without the need for a Zener barrier or galvanic isolator - see A1.3.2.2

Appendix 2

IECEX Certification

A2.0 The IECEx Certification Scheme

IECEX is a global certification scheme for explosion protected products which aims to harmonise international certification standards.

For additional information about the IECEx certification scheme and to view the BEKA associate certificates, please visit www.iecex.com

A2.1 IECEx Certificate of Conformity

The BA327C and BA328C loop powered indicators have been issued with an IECEx Certificate of Conformity number IECEx ITS 05.0003 which specifies the following certification code and marking:

Ex ia IIC T5
Ta = -40°C to 60 °C

The specified intrinsic safety parameters are identical to the ATEX safety parameters.

The IECEx certificate may be downloaded from www.beka.co.uk, www.iecex.com or requested from the BEKA sales office.

A2.2 Installation

The IECEx and ATEX certificates specify identical safety parameters and installation requirements for both approvals is defined by EN 60079-14. The ATEX installation requirements specified in section 5 of this manual may therefore be used for IECEx installations, but the local code of practice should also be consulted.