

**BA307C & BA308C  
Intrinsically safe  
loop-powered  
3½ digit panel  
mounting indicators**

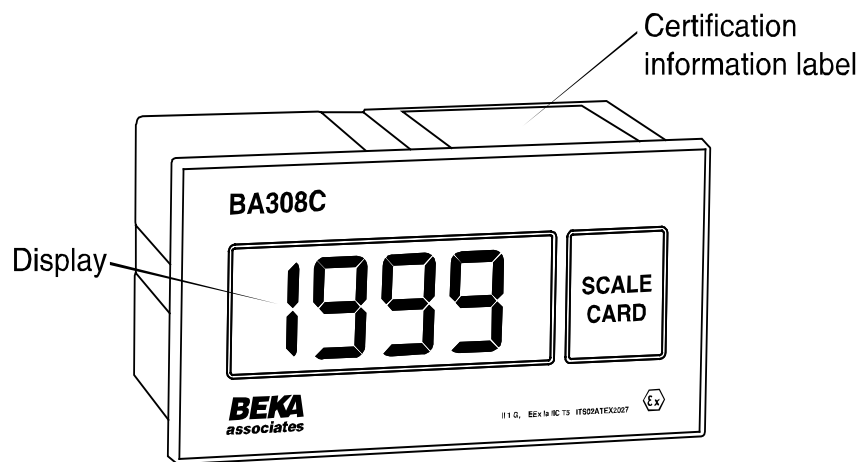

**CONTENTS**

- 1. Description**
  - 2. Operation**
  - 3. Intrinsic Safety Certification**
    - 3.1 ATEX certificate
    - 3.2 4/20mA input
    - 3.3 Zones, gas groups & T rating
    - 3.4 Certification label information
  - 4. System Design for Hazardous Areas CENELEC certification**
    - 4.1 Transmitter loops
    - 4.2 Remote indication
  - 5. Installation**
    - 5.1 Location
    - 5.2 Installation procedure
    - 5.3 EMC
  - 6. Calibration**
    - 6.1 Zero adjustment
    - 6.2 Span adjustment
    - 6.3 Decimal point
    - 6.4 Reverse action
    - 6.5 Calibration example
    - 6.6 Over and under-range
  - 7. Maintenance**
    - 7.1 Fault finding during commissioning
    - 7.2 Fault finding after commissioning
    - 7.3 Servicing
    - 7.4 Routine maintenance
    - 7.5 Guarantee
    - 7.6 Customer comments
  - 8. Accessories**
    - 8.1 Scale card
    - 8.2 Tag strip
    - 8.3 Internal calibrator
    - 8.4 Root extractor
      - 8.4.1 Calibration example
    - 8.5 Display backlights
      - 8.5.1 Separately powered
      - 8.5.2 Loop powered
- Appendix 1** FM Approval for use in USA
- Appendix 2** IECEx Certification

The BA307C and BA308C indicators are CE marked to show compliance with the European Explosive Atmospheres Directive 94/9/EC and the European EMC Directive 89/336/EEC

## 1. DESCRIPTION

The BA307C and BA308C are intrinsically safe loop powered 3½ digit indicators that display the current flowing in a 4/20mA loop in engineering units. Both instruments introduce less than a 1.1V drop which allows them to be installed into almost any 4/20mA current loop. No additional power supply or battery is required.

The two indicators are electrically similar, but have different size displays and enclosures.

Model	Display height	Bezel size
BA307C	12.7mm	96 x 48mm
BA308C	25.4mm	144 x 72mm

The main application of the BA307C and BA308C is to display a measured variable or control signal in a hazardous process area. The zero and span of the display are independently adjustable so that the indicators can be calibrated to display any variable represented by the 4/20mA current, e.g. temperature, flow, pressure or level.

The BA307C and BA308C have been certified intrinsically safe by ITS Testing and Certification Ltd to the European ATEX Directive 94/9/EC. The EC-Type Examination certificate specifies that under fault conditions the voltage, current and power at the input terminals of each instrument will not exceed those specified for *simple apparatus* in Clause 5.4 of EN50020:1994.

The BA307C and BA308C are also FM approved for use in the USA, this approval is described in Appendix 1.

International IECEx certification is described in Appendix 2.

## 2. OPERATION

Fig 1 shows a simplified block diagram of both models. The 4/20mA input current flows through resistor R1 and forward biased diode D1. The voltage developed across D1, which is relatively constant, is multiplied by a switch mode power supply and used to power the analogue to digital converter and liquid crystal display. The voltage developed across R1, which is proportional to the 4/20mA input current, provides the input signal for the analogue to digital converter.

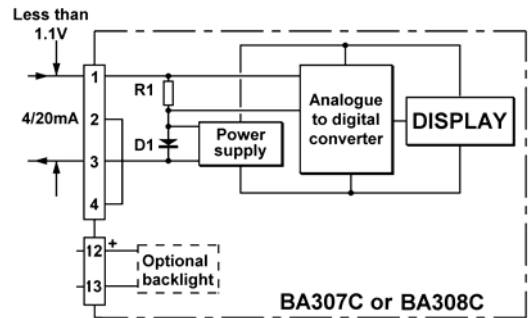

Fig 1 Simplified block diagram of BA307C and BA308C

## 3. INTRINSIC SAFETY CERTIFICATION

### 3.1 ATEX certificate

The BA307C and BA308C have been issued with an EC-Type Examination Certificate number ITS02ATEX2027 by Notified Body ITS Testing and Certification Ltd. This confirms compliance with the European ATEX Directive for Group II, Category 1 G equipment, EEx ia IIC T5. The instrument bears the Community Mark and, subject to local codes of practice, may be installed in any of the European Economic Area (EEA) member countries. ATEX certificates are also acceptable for installations in Switzerland. This manual describes installations which conform with BS EN60079:Part14:1997 Electrical Installation in Hazardous Areas. When designing systems for installation outside the UK, the local Code of Practice should be consulted.

### 3.2 4/20mA input

In Europe, sources of energy which do not generate more than 1.5V; 100mA or 25mW are, for intrinsic safety purposes, considered to be *simple apparatus* (Clause 5.4 of EN50020:1994).

Although the BA307C and BA308C indicators do not themselves comply with the requirements for *simple apparatus*, the EC-Type Examination Certificate specifies that under fault conditions the voltage, current and power at the 4/20mA input terminals 1 & 3 will not exceed those specified for *simple apparatus* in Clause 5.4 of EN50020:1994. This allows the BA307C and BA308C to be connected into any intrinsically safe circuit protected by a Zener barrier or galvanic isolator providing the output parameters of the circuit do not exceed:

$$\begin{aligned} U_o &= 30V \text{ dc} \\ I_o &= 200\text{mA} \\ P_o &= 0.85W \end{aligned}$$

The EC-Type Examination Certificate specifies that the maximum equivalent capacitance and inductance between the two 4/20mA input terminals 1 and 3 is:

$$\begin{aligned} C_i &= 20\text{nF} \\ L_i &= 10 \text{ H} \end{aligned}$$

To determine the maximum permitted cable parameters, these figures should be subtracted from the maximum cable capacitance and inductance permitted by the certificate for the loop into which the indicator is installed.

### 3.3 Zones, gas groups and T rating

The BA307C and BA308C have been certified as Group II, Category 1G, EEx ia IIC T5 apparatus at Tamb –40 to 60°C. When connected to a suitable system the instruments may be installed in:

- Zone 0 explosive gas air mixture continuously present.
- Zone 1 explosive gas air mixture likely to occur in normal operation.
- Zone 2 explosive gas air mixture not likely to occur, and if it does will only exist for a short time.

Be used with gases in groups:

- Group A propane
- Group B ethylene
- Group C hydrogen

Having a temperature classification of:

- T1 450°C
- T2 300°C
- T3 200°C
- T4 135°C
- T5 100°C

At ambient temperatures between –40 & +60°C. Note: Operation only specified between –20°C and + 60°C.

This allows both indicators to be installed in all Zones and to be used with most common Industrial gases.

### 3.4 Certification label information

The certification label is fitted in a recess on the top outer surface of the enclosure. It shows the ATEX certification information, instrument serial number, year of manufacture plus BEKA associates' name and location. Non European certification information may also be included.

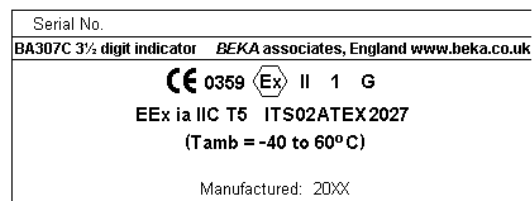

BA307C certification label

## 4. SYSTEM DESIGN FOR HAZARDOUS AREAS

### 4.1 Transmitter loops

The BA307C and BA308C may be connected in series with almost any intrinsically safe 4/20mA current loop and calibrated to display the measured variable or control signal in engineering units. There are two basic design requirements:

1. The intrinsic safety output parameters of the 4/20mA loop, which are defined by the Zener barrier or galvanic isolator, must be equal to or less than:

$$\begin{aligned} U_o &= 30V \text{ dc} \\ I_o &= 200mA \\ P_o &= 0.85W \end{aligned}$$

2. The loop must be able to tolerate the additional 1.1V required to operate the indicator.

Fig 2 illustrates a typical application in which an indicator is connected in series with a 2-wire transmitter protected by a Zener barrier.

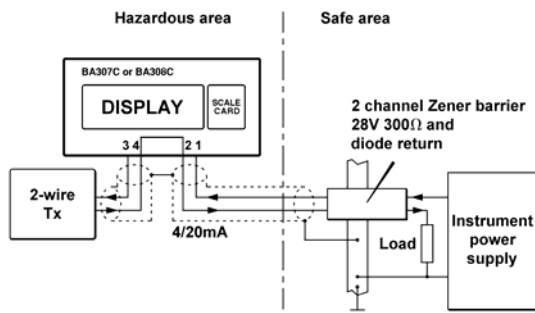

Fig 2 BA307C or BA308C in a transmitter loop

### 4.2 Remote indication

BA307C and BA308C indicators may be driven via an intrinsically safe interface from a 4/20mA safe area signal to provide a remote indication within a hazardous area. The type of interface is not critical, either a Zener barrier or a galvanic isolator may be used, providing that  $U_o$ ,  $I_o$  and  $P_o$  are not exceeded.

If one side of the 4/20mA current loop may be earthed, a single channel Zener barrier provides the lowest cost protection. If the 4/20mA signal is not isolated, then two Zener barriers, a two channel Zener barrier or a galvanic isolator should be used. Again it is necessary to ensure that the voltage capability of the 4/20mA signal is sufficient to drive the indicator plus the voltage drop introduced by the intrinsically safe interface. Fig 3 shows the alternative circuits which may be used.

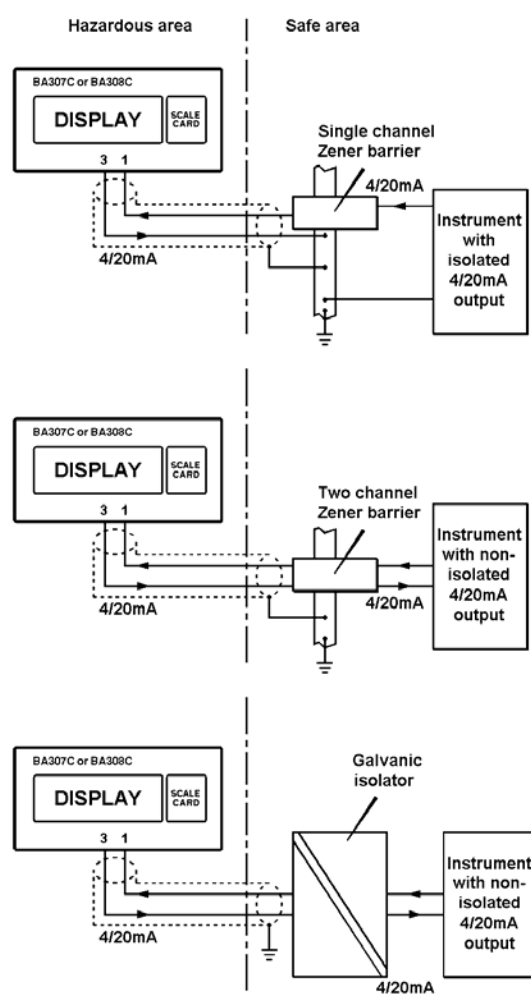

Fig 3 Alternative circuits for remote indication in hazardous area

## 5. INSTALLATION

### 5.1 Location

BA307C and BA308C indicators are housed in robust aluminium enclosures with a polyester front panel and a Noryl bezel. The front of both instruments provide IP65 protection and a gasket seals the joint between the instrument and the panel. The indicators may be installed in any instrument panel providing the environmental limits shown in the specification are not exceeded.

Figs 4A and 4B show the overall dimensions of each instrument and the size of the required panel cut-out. To achieve an IP65 seal between the instrument enclosure and the instrument panel the smaller tolerance aperture should be used and the BA308C must be secured with four mounting clips.

### Cut-out Dimensions

#### DIN 43 700

$92.0 +0.8/-0.0 \times 45.0 +0.6/-0.0$

To achieve an IP65 seal  
between BA307C and instrument  
panel

$90.0 +0.5/-0.0 \times 43.3 +0.5/0.0$

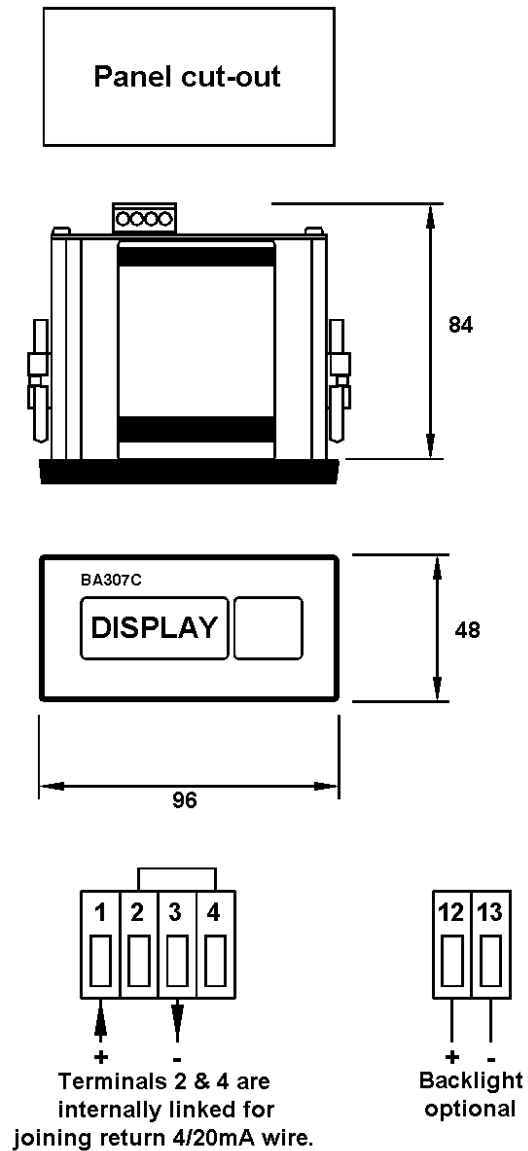

Fig 4A BA307C dimensions

### Cut-out Dimensions

#### DIN 43 700

138.0 +1.0/-0.0 x 68.0 +0.7/-0.0

To achieve an IP65 seal  
between BA308C and instrument  
panel

138.0 +0.5/-0.0 x 66.2 +0.5/0.0

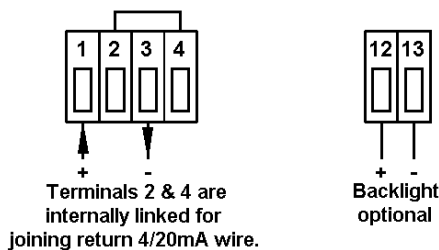
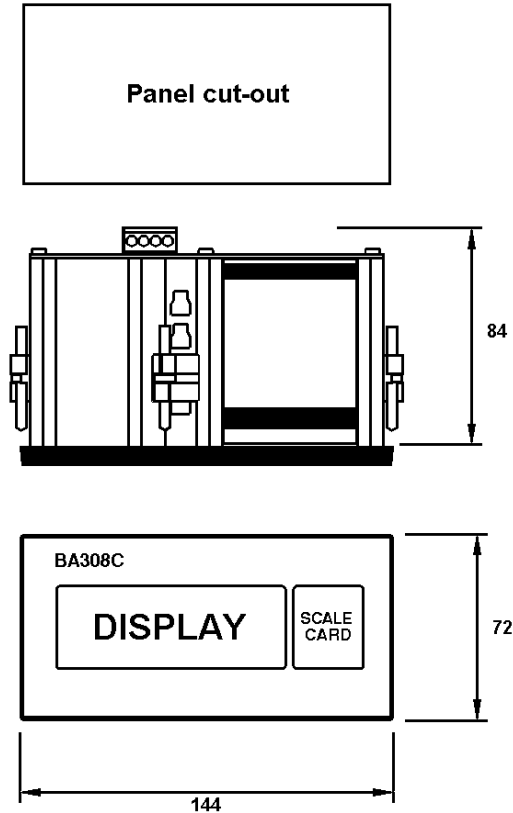

Fig 4B BA308C dimensions

## 5.2 Installation Procedure

- Insert the indicator into the panel aperture from the front of the panel.
- Fix two panel mounting clips to opposite sides of the instrument enclosure and tighten until the indicator is secure as shown in Fig 5. Four clips are required to achieve an IP65 seal between a BA308C enclosure and the instrument panel.
- Connect the panel wiring to the rear terminal block(s) as shown in Figs 4A and 4B. To simplify installation, the terminals are removable so that the panel wiring can be completed before the instrument is installed.

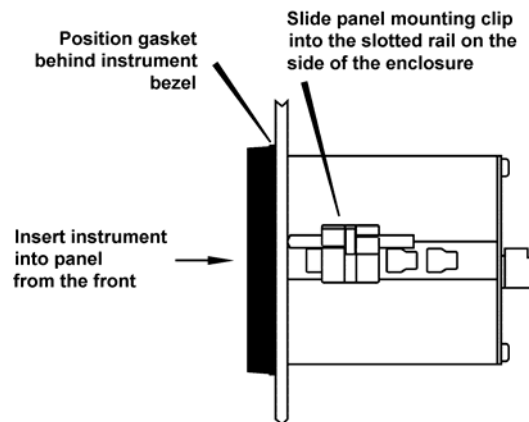

Fig 5 Fitting panel mounting clips

## 5.3 EMC

Both instruments comply with the requirements of the European EMC Directive 89/336/EEC. For specified immunity all 4/20mA wiring should be in screened twisted pairs with the screen earthed within the safe area. The indicator enclosure may be earthed locally by putting a tag under one of the rear panel corner fixing screws. EMC performance is shown in the instrument specification, and copies of the test report are available from BEKA associates.

### 6. CALIBRATION

The BA307C and BA308C will be supplied calibrated as requested at time of ordering. If calibration is not requested, the indicator will be set to display 00.0 with 4.000mA input, and 100.0 with 20.000mA input.

Both instruments are conditioned and calibrated by plug-in links and two multi-turn potentiometers. The potentiometers are accessible through holes in the rear panel, but the rear panel must be removed to gain access to the plug-in links - see Fig 6.

For maximum accuracy, indicators should be calibrated using an external traceable current source with an accuracy greater than 4 A. However, when verification is not required the indicator can be fitted with an optional internal calibrator which allows rapid calibration without the need for external instruments. See section 8.3 for details.

#### 6.1 Zero adjustment

Zero is defined as the number displayed by the indicator with a 4.000mA input current, and may be adjusted between -1000 and 1000. The zero potentiometer has two ranges, 0 to 500 and 500 to 1000. Zero polarity is defined by the position of the suppression / elevation links which are shown in Fig 7.

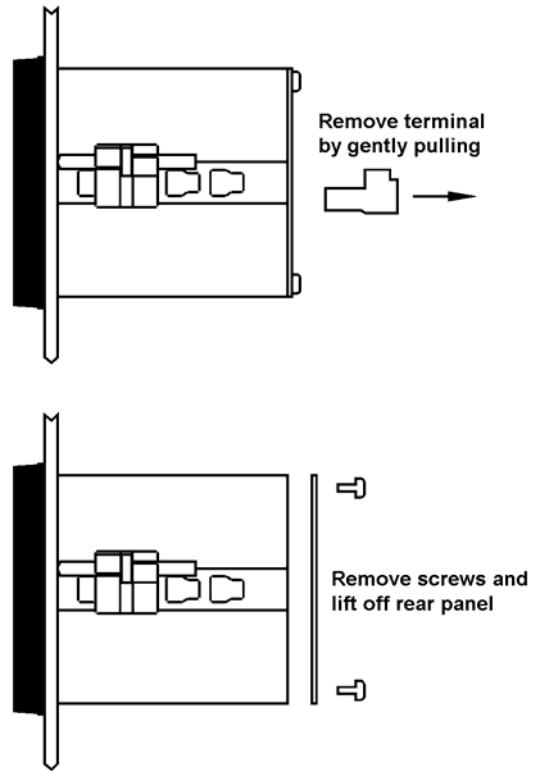

Fig 6 Removal of rear panel

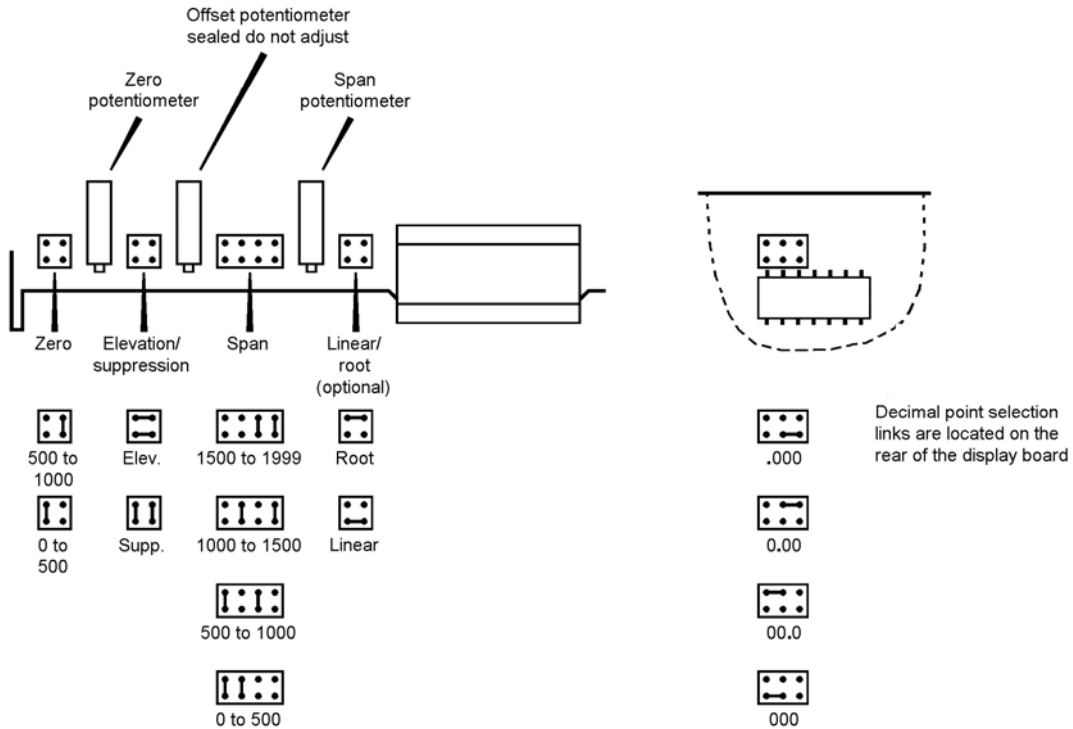

Fig 7 Position of plug-in calibration links and potentiometers

### Suppression / elevation links

Position see Fig 7	Display with 4mA input adjustable Between
Elevation	0 and 1000
Suppression	0 and -1000

### Zero link

Position see Fig 7	Display with 4mA Input adjustable Between
0 to 500	0 and 500
500 to 1000	500 and 1000

### 6.2 Span adjustment

Span is defined as the difference between the number displayed with 4.000mA input and the number displayed with 20.000mA input. It is adjustable between 0 and 1999 in four ranges. Fig 7 shows the position of the span links and the span potentiometer.

#### Span links

Position see Fig 7	Difference in Display with 4 & 20mA input adjustable between
000 to 500	000 and 500
500 to 1000	500 and 1000
1000 to 1500	1000 and 1500
1500 to 1999	1500 and 1999

### 6.3 Decimal point

A decimal point may be displayed between any of the four digits. The position or absence of this dummy decimal point is determined by the position of the decimal point link shown in Fig 7. When calculating the required span and zero setting, the decimal point should be ignored.

### 6.4 Reverse action

Normally the instrument display increases as the input current increases, but this can be reversed. Please contact BEKA associates for details.

### 6.5 Calibration example

A BA307C is required to display:

25.0 with a 4.000mA input

115.0 with a 20.000mA input

i.e. A zero of positive 250 } Ignoring  
A span of 900 } decimal point  
A decimal point in position 00.0

The following adjustments are required:

- Step 1 The BA307C is required to display a positive zero therefore the suppression / elevation links should be put in the elevation position.
- Step 2 The required zero is 250, therefore the zero link should be put in the 0 to 500 position.
- Step 3 The required span is 900, therefore the span links should be placed in the 500 to 1000 position.
- Step 4 The decimal point is required before the least significant digit, therefore the decimal point link should be placed in the 00.0 position.
- Step 5 With 4.000mA input adjust the zero potentiometer until the indicator displays 25.0
- Step 6 With 20.000mA input adjust the span potentiometer until the indicator displays 115.0
- Step 7 Repeat steps 5 and 6 until both calibration points are correct. The span and zero controls are almost independent so it should only be necessary to repeat each adjustment twice.

### 6.6 Over and under-range

If the indicator display range is exceeded, the three least significant digits will be blanked. Under-range is indicated by -1 and over-range by 1. If the display range is not exceeded, both indicators will produce accurate readings outside the 4/20mA current range. Although not guaranteed, most BA307C and BA308C indicators will operate between 3 and 25mA.

## 7. MAINTENANCE

### 7.1 Fault finding during commissioning

If a BA307C or BA308C fails to function during commissioning the following procedure should be followed:

Symptom	Cause	Solution
No display	Incorrect Wiring	There should be 1V between terminals 1 & 3 with terminal 1 positive.
No display and 0V between terminals 1 and 3.	Incorrect wiring or no power supply.  Insufficient loop voltage to operate indicator.	Check that a current is flowing in the loop.  Check supply voltage and voltage drops caused by all components in the loop.
Indicator displays 1	Positive over-range	The indicator has been incorrectly calibrated & is trying to display a number greater than 1999.
Indicator displays -1	Negative over-range	The indicator has been incorrectly calibrated & is trying to display a number less than -1999.
Unstable display	4/20mA input has a large ripple	Check loop supply voltage.

### 7.2 Fault finding after commissioning

#### ENSURE PLANT SAFETY BEFORE STARTING MAINTENANCE

**Live maintenance is permitted on intrinsically safe equipment installed in a hazardous area, but only certified test equipment should be used unless a gas clearance certificate is available.**

If a BA307C or BA308C fails after it has been functioning correctly, the following procedure should be followed:

Symptom	Cause	Solution
No display and 0V between terminals 1 and 3	No power supply	Check that a current is flowing in the loop.
Unstable display	4/20mA input has a large ripple	Check loop supply voltage.

If this procedure does not reveal the cause of The fault, it is recommended that the indicator is replaced.

### 7.3 Servicing

All standard BA307C and BA308C indicator assemblies are interchangeable and a single spare may be used to replace any instrument which fails.

**We recommend that faulty instruments and instrument assemblies are returned to BEKA associates or your local BEKA agent for repair.**

### 7.4 Routine maintenance

The mechanical condition of the instrument and the electrical calibration should be regularly checked. The interval between inspections depends upon the environmental conditions. We recommend that initially instrument calibration is checked annually.

### 7.5 Guarantee

Indicators which fail within the guarantee period should be returned to BEKA associates or our local agent. It is helpful if a brief description of the fault symptoms is provided.

### 7.6 Customer comments

BEKA associates is always pleased to receive comments from customers about our products and services. All communications are acknowledged and whenever possible suggestions are implemented.

## 8. ACCESSORIES

### 8.1 Scale card

The BA307C and the BA308C have a window on the right hand side of the display to hold a card showing the units of measurement e.g. °C, mBar, RPM. Indicators can be supplied with a printed scale card showing any units specified at the time of ordering. If a printed scale card is not requested, a blank card will be supplied.

Scale cards can easily be marked on site as follows:

- Remove the rear terminal block and the rear panel as shown in Fig 6.
- Carefully pull the indicator assembly from the enclosure.
- Gently pull and then slide the blank scale card towards the display window until it is free. Mark the card with the required legend and replace in the slot.

### 8.2 Tag strip

The BA307C and the BA308C can be supplied with a thermally printed tag number on the rear panel. This tag number is not visible from the front of the instrument after installation.

### 8.3 Internal Calibrator

Both indicators can be supplied with an optional internal calibrator which simulates 4 and 20mA input currents. This allows rapid calibration without the need for external instruments or disconnection from the 4/20mA input current, but it is not a substitute for calibration with a traceable external current source. Fig 8 shows the position of the calibration links.

The internal calibrator can not be fitted to an instrument with a root extractor.

To calibrate the instrument using the internal calibrator, the following procedure should be followed. This may be done with any input current between 4 and 20mA.

- Put the suppression / elevation, zero, span and decimal point links in the required position.
- Put the calibrator link in the 4mA position and adjust the zero potentiometer to give the required display at 4mA.
- Put the calibrator link in the 20mA position and adjust the span potentiometer to give the required display at 20mA.
- Repeat steps 2 and 3 until both calibration points are correct. The span and zero controls are almost independent so it should only be necessary to repeat each adjustment twice.
- Return the calibrator link to 'indicate' position. The indicator will now respond to the 4/20mA input current with the revised calibration.

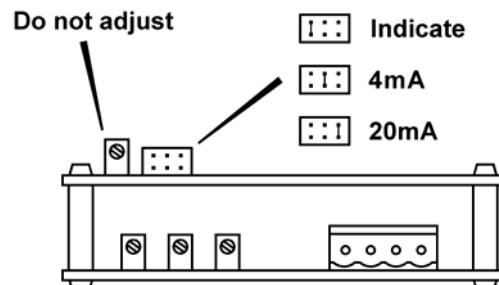

Fig 8 position of internal calibrator links

### 8.4 Root extractor

A square root extractor can be fitted to both the BA307C and BA308C enabling them to accurately display the output from a differential flow meter in linear engineering units between 10 and 100% of full flow (4.16 to 20mA). The lineariser continues to operate with reduced accuracy down to 2.5% of maximum flow, or clip-off can be selected which will force the display to zero at flows below 5% (4.04mA). The location of the clip-off plug-in link is shown in Fig 9.

When calibrating a BA307C or BA308C fitted with a root extractor the zero potentiometer should be adjusted to give the required display at 10% of flow (4.16mA). The zero potentiometer should not be used to set the display to zero with a 4mA input. Zero suppression or elevation may not be used, i.e. 4mA must correspond to zero flow.

For reference, the following table shows the output current from a non-linearised differential flowmeter.

% of full flow	Current output mA
2.5	4.01
10.0	4.16
25.0	5.00
50.0	8.00
75.0	13.00
100.0	20.00

A root extractor can not be fitted to an instrument with an internal calibrator.

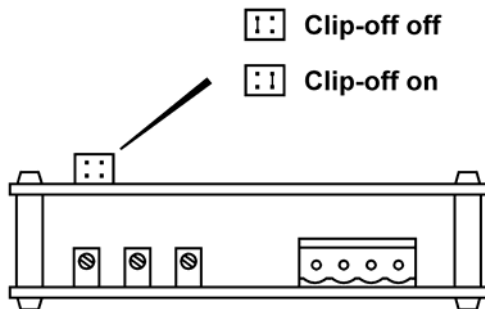

Fig 9 Location of clip-off link

### 8.4.1 Calibration example with root extractor

The indicator is required to display rate of flow in gallons per minute, with a resolution of 0.1 gallons. The differential flowmeter has an output of 20mA at a flow rate of 140.0 gallons per minute.

- i.e. A span of 1400 ignoring the decimal point  
A decimal point in position 00.0

The following adjustments are required:

- Step 1 Put the suppression / elevation links in the elevation position.
- Step 2 Put the zero link in the 0 to 500 position.
- Step 3 The required span is 1400, therefore the span links should be placed in the 1000 to 1500 position.
- Step 4 The decimal point is required between the least two significant digits, therefore the decimal point link should be placed in the 00.0 position.
- Step 5 With 4.160mA input current adjust the zero potentiometer until the indicator displays 14.0 (10% of flow). If there is insufficient adjustment to achieve this, put the elevation/suppression links in the suppression position and continue with the calibration procedure.
- Step 6 With 20.000mA input current adjust the span potentiometer until the indicator displays 140.0
- Step 7 Repeat steps 5 and 6 until both calibration points are correct.

**8.5 Display backlights**

The BA307C & BA308C indicators can be supplied with one of two types of backlight. The loop powered backlight produces green background illumination enabling the display to be read at night or in poor lighting conditions. No additional power supply, IS interface or field wiring are required, but the indicator voltage drop is increased. Alternatively, the separately powered backlight has a bright orange output which enhances daylight viewing, but an additional IS interface and field wiring are required.

**8.5.1 Separately powered backlight**

The separately powered backlight is segregated from the measuring circuit and has been certified as a separate intrinsically safe circuit, but it does not comply with the requirements for simple apparatus.

This backlight must be powered from the safe area via a Zener barrier or a galvanic isolator as shown in Fig 10. Any certified device may be used, providing the output parameters do not exceed:

$$\begin{aligned} U_o &= 28V \text{ dc} \\ I_o &= 110mA \\ P_o &= 0.77W \end{aligned}$$

For guidance, System Certificates ITS No Ex02E2029 and 2030 have been issued which list some of the devices that may be used.

The EC-Type Examination Certificate specifies that the maximum equivalent capacitance and inductance between terminals 12 and 13 is:

$$\begin{aligned} C_i &= 0.045\mu F \\ L_i &= 0.02mH \end{aligned}$$

To determine the maximum permitted cable parameters, these figures should be subtracted from the maximum permitted cable capacitance and inductance specified by the certificate for the Zener barrier or galvanic isolator powering the backlight.

For guidance, System Certificates ITS No Ex02E2029 and 2030 have been issued which list some of the devices that may be used.

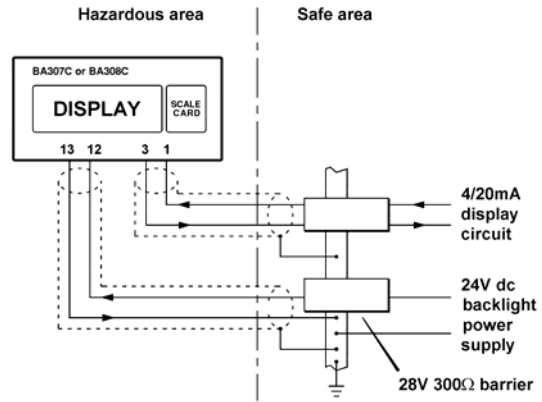

Fig 10 Backlight power supply

The display brilliance depends upon the current flowing through the backlight which is determined by the supply voltage and the end-to-end resistance of the Zener barrier or output resistance of the galvanic isolator. Brilliance will not be significantly reduced until the current falls below 20mA.

The BA307C backlight requires a minimum supply voltage of 14V, and the larger BA308C backlight a minimum supply voltage 18V. The backlight current can be calculated from:

For a BA307C

$$\text{Backlight current} = \frac{V_{\text{supply}} - 14}{\text{End-to-end resistance of barrier\#}}$$

For a BA308C

$$\text{Backlight current} = \frac{V_{\text{supply}} - 18}{\text{End-to-end resistance of barrier\#}}$$

# or output resistance of galvanic isolator

Two indicator backlights may be powered in parallel from a single 28V 300 Zener barrier or galvanic isolator, but the display brilliance will be reduced.

### 8.5.2 Loop powered backlight

This backlight may be connected in series with the 4/20mA measuring circuit so that like the indicator it is loop powered. This eliminates the need for a separate Zener barrier or galvanic isolator and associated wiring for the backlight, thus significantly reducing the installation cost.

As shown in Fig 11 the backlight may be connected in series with the indicator. Any Zener barrier or galvanic isolator certified EEx ia IIC by an EEC approved certification body may be used providing the output parameters do not exceed:

$$\begin{aligned} U_o &= 30V \text{ dc} \\ I_o &= 200mA \\ P_o &= 0.85W \end{aligned}$$

For guidance, System Certificates ITS No Ex02E2031 and 2032 have been issued which list some of the devices that may be used.

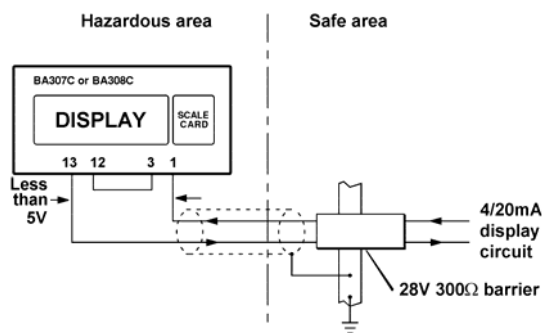

Fig 11 Loop powered backlight

Connecting the backlight in series with the indicator will increase the total voltage drop in the 4/20mA measuring loop from 1.1V to 5.0V

**Appendix 1**  
**FM approval for use in USA**

**A1.0 Factory Mutual Approval**

For installations in the USA, the BA307C, BA308C and accessories have been approved intrinsically safe and nonincendive by FM Approvals, project identification 4B3A7.AX-1. Copies of the Certificate of Compliance are available from the BEKA associates sales office and from the BEKA web site [www.beka.co.uk](http://www.beka.co.uk).

**A1.1 Intrinsic safety approval**

The BA307C and BA308C are approved to the FM Class 3610 intrinsic safety standard. Installations must comply with BEKA associates Control Drawing CI300-22, which is attached to this Appendix, ANSI/ISA RP12.06.01 'Installation of Intrinsically Safe Systems for Hazardous (Classified) Locations' and with the National Electrical Code ANSI/NFPA70.

The BA307C and BA308C have a T4 rating at ambient temperatures between -20°C and +60°C and may be used in the following divisions with the following gases:

<b>Intrinsic Safety</b>	
Division 1 or 2	
Class I	Group A & B Group C Group D

The FM entity parameters are similar to the ATEX parameters. The intrinsically safe circuits shown in this manual may therefore be used for installations in the USA, providing the Zener barriers and galvanic isolators are FM Approved and comply with BEKA associates Control Drawing CI300-22.

**A1.2 Nonincendive approval**

The BA307C and BA308C have been approved to the Class 3611 nonincendive standard by Factory Mutual allowing them to be installed in Division 2 Classified Areas without the need for Zener barriers or galvanic isolators. Installations must comply with the National Electrical Code ANSI/NFPA70.

The BA307C and BA308C have a T4 rating at ambient temperatures between -20°C and +60°C and may be used with the following gases:

<b>Nonincendive</b>	
Division 2	
Class I	Group A & B Group C Group D

Appd.		 <p style="font-size: small;">company confidential, copyright reserved.</p>	Modification		
Ckd.			Date		
Iss.			Date		
Iss.	3		Date	26.05 2005	Modification
Appd.	.	Ckd.	.	Appd.	.

### HAZARDOUS (CLASSIFIED) LOCATION

BA304C LOCATIONS:  
Class I, Division 1, Groups A, B,C & D  
Class II, Division 1, Groups E, F & G  
Class III

BA307C & BA308C LOCATIONS:  
Class I, Division 1, Groups A, B,C & D

BA304C, BA307C or BA308C Entity Parameters

Terminals 1, 2, 3 & 4  
 $V_{max} = 32V$   
 $I_{max} = 200mA$   
 $P_{max} = 1.2W$   
 $C_i = 0.02\mu F$   
 $L_i = 0.01mH$

Terminals 12 & 13  
 $V_{max} = 32V$   
 $I_{max} = 159mA$   
 $P_{max} = 1.2W$   
 $C_i = 0.03\mu F$   
 $L_i = 0.01mH$

### UNCLASSIFIED LOCATION

SEE NOTE 1

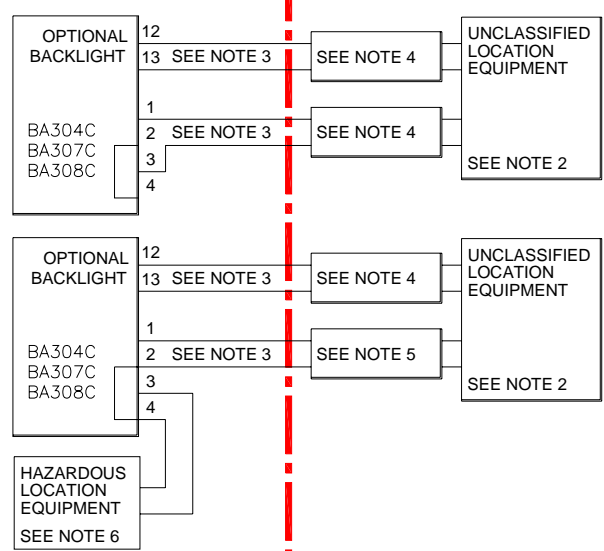

**Note:**  
No modification to be made without reference/approval from FM Approvals and BEKA Associates Design Department.

**Notes:**

1. The associated intrinsically safe barriers or galvanic isolators must be FM approved and the manufacturers' installation drawings must be followed when installing this equipment.
2. The unclassified location equipment connected to the associated intrinsically safe barriers or galvanic isolators must not use or generate more than 250V rms or 250V dc.
3. Installation should be in accordance with ANSI/ISA RP 12.06.01 "Installation of Intrinsically Safe Systems for Hazardous (Classified) Locations" and the National Electrical Code ANSI/NFPA 70.
4. One single channel or one channel of a dual channel barrier or galvanic isolator with entity parameters complying with the following requirements:

Voc or Vt	equal to or less than	Vmax
Isc or It	equal to or less than	Imax
Po	equal to or less than	Pmax
La	equal to or greater than	Lcable + Li
Ca	equal to or greater than	Ccable + Ci

Title

FM Control Drawing for BA304C, 307C and 308C

Drawn	Checked	Scale
RC		N/A

Drawing No.  
Sheet 1 of 2 C1300-22



## **Appendix 2 IECEX Certification**

### **A2.0 The IECEX Certification Scheme**

IECEX is a global certification scheme for explosion protected products which aims to harmonise international certification standards.

For additional information about the IECEX certification scheme and to view the BEKA associate certificates, please visit [www.iecex.com](http://www.iecex.com)

### **A2.1 IECEX Certificate of Conformity**

The BA307C and BA308C loop powered indicators have been issued with an IECEX Certificate of Conformity number IECEX ITS 05.0002 which specifies the following certification code and marking:

Ex ia IIC T5  
Ta = -40°C to 60°C

The specified intrinsic safety parameters are identical to the ATEX safety parameters.

The IECEX certificate may be downloaded from [www.beka.co.uk](http://www.beka.co.uk), [www.iecex.com](http://www.iecex.com) or requested from the BEKA sales office.

### **A2.2 Installation**

The IECEX and ATEX certificates specify identical safety parameters and installation requirements for both approvals is defined by IEC 60079-14. The ATEX installation requirements specified in section 5 of this manual may therefore be used for IECEX installations, but the local code of practice should also be consulted.