



WHITE PAPER

ADDRESSABLE GAS DETECTION SYSTEMS

March 2009

By Paul Lazor, Sales & Marketing Director

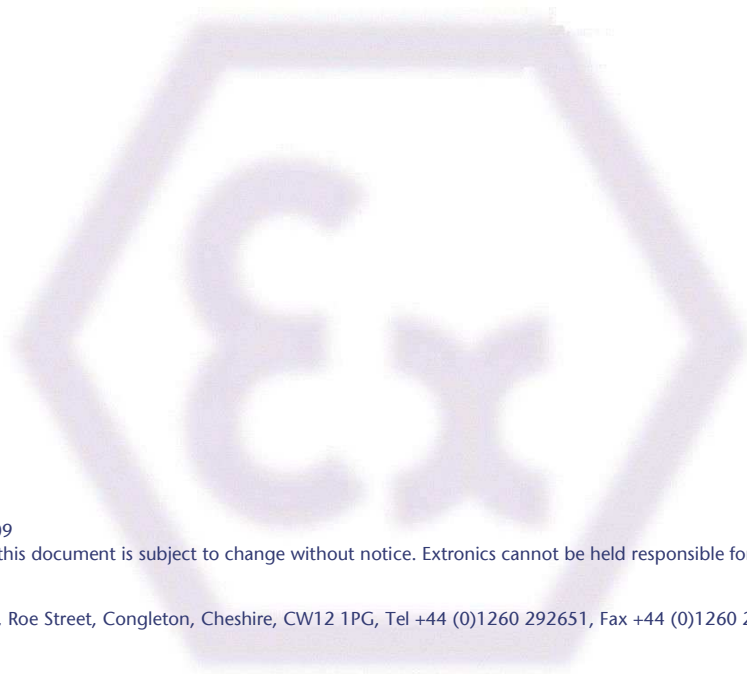

Copyright © Extronics Ltd 2009

The information contained in this document is subject to change without notice. Extronics cannot be held responsible for any errors or inaccuracies within this document.

Extronics Ltd, Meridian House, Roe Street, Congleton, Cheshire, CW12 1PG, Tel +44 (0)1260 292651, Fax +44 (0)1260 297280 | www.extronics.com

Addressable Gas Detection Systems

Cabling Costs and Space Issues

Analogue Gas detection systems serve many applications and are installed across the whole spectrum of industry. These systems have provided solutions to monitoring problems for many years gathering information on changing levels of gas for trending and logging applications or as part of safety warning/shutdown systems for Toxic and Flammable gas applications.

Tried and Proven technology with a long and established history in a market requires comparative understanding to determine whether there is an alternative solution. However it is not necessarily the case that the new and modern is better, an application should be assessed on its requirements and the various solutions carefully scrutinised to identify the best solution.

This short paper is intended to draw on comparisons and extol the virtues of addressable systems but also to keep them within context so that when selected they are chosen for the right reasons.

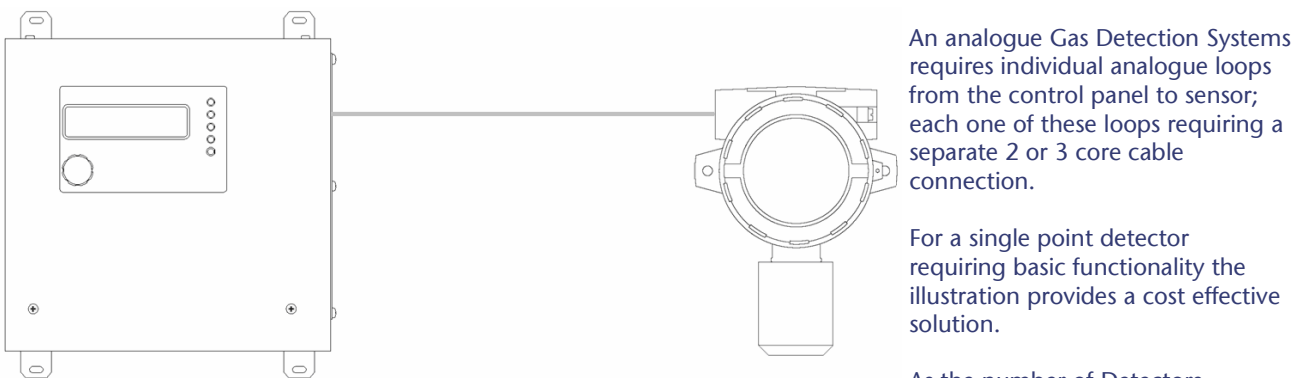

As the number of Detectors required increases the amount of cabling that is required to meet with the architecture of the Gas Detection System increases dramatically. Even If the application is in a relatively small confined area, then the increased amount of cabling can still present a major cost burden especially when the cable containment and installation labour issues are included. Subsequently this mass of cabling and termination requires housing either by termination in the control panel or to avoid confusion on large installations in a separate marshalling box or boxes.

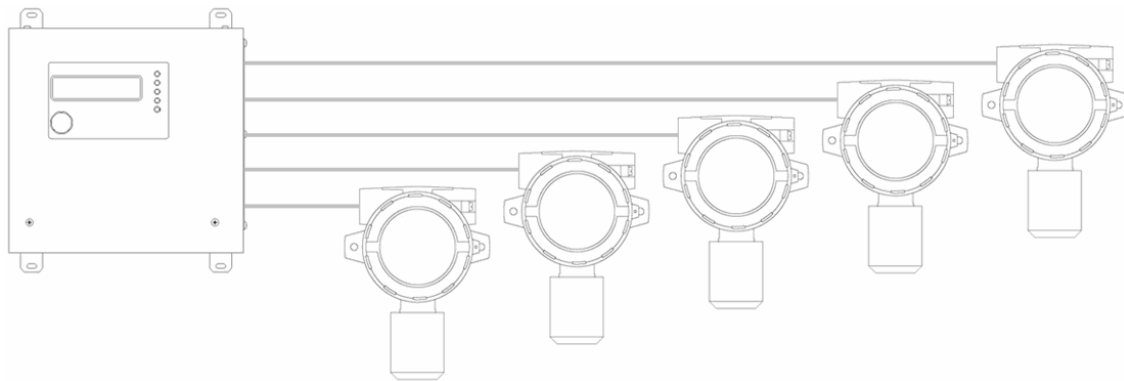

The increased time frame to undertake such a task can place a large labour cost burden on the project as well as increasing the hardware costs to accommodate the large amount of cabling.

It is therefore important to consider the following issues when considering an installation:

- CABLING COSTS
- CONTAINMENT COSTS
- CONSTRUCTION ISSUES
- HIGH LABOUR REQUIREMENTS
- ADDITIONAL HARDWARE COSTS
- TIME

Taking all of the above factors into consideration can potentially result in costs that are substantially larger than the actual cost of the gas detection equipment.

Addressable Solutions

A Gas Detection system based on an addressable highway simplifies the whole process of installation by radically reducing the time necessary to install and terminate the cable required for the system as well as dramatically reducing the amount of cable that is necessary.

The loop consists of 4 cores; two provide the 24VDC to power the field devices and the two cores for communication. This single highway cable is used to interconnect all the field devices, either as a spur or looped back to the panel as a ring highway.

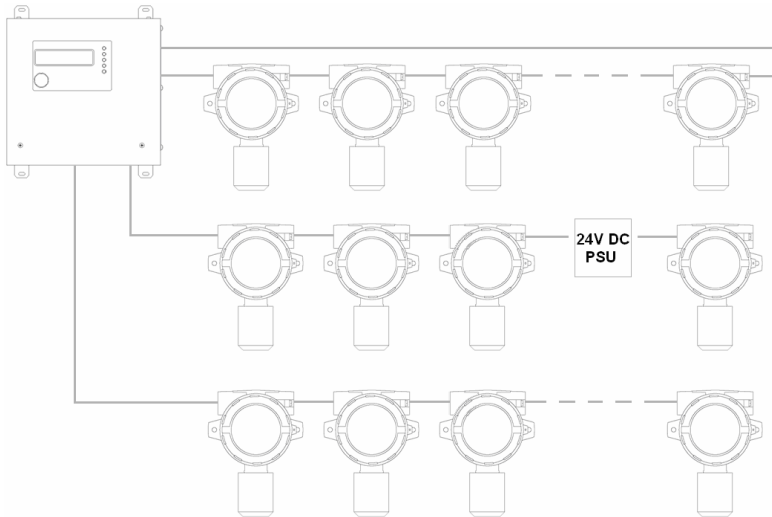

The four core cable highway can be used in safe or hazardous areas when interfaced with ATEX certified Detectors.

Unlike an Analogue system addressable systems can integrate other devices into the loop including Beacons and Sounders and Relays can be utilised on the highway providing the user with a high level of flexibility when designing the system, allowing for audio visual alarms to be located in those isolated areas to warn operator personnel of impending danger is crucial.

This added benefit further reduces cable runs by eliminating the connection of the Audio visual alarm back to the main control panel.

Depending upon distances and the number of detectors, field alarm devices can be powered from the loop again reducing costs.

As an illustration of the dramatic differences between the cost of cabling an Analogue System and an Addressable System an Oil Terminal provided factual data comparing various costs and statistics.

The calculated analogue system cable run required for the application was 62Km of Cable; by comparison the addressable system required only 11Km of Cable. Whilst the saving provided by eliminating 51Km of cable is substantial the cost saving by reducing the number of cable tray runs, eliminating field marshalling panels and the massive reduction in labour clearly illustrates the phenomenal reductions in costs that an addressable system can bring.

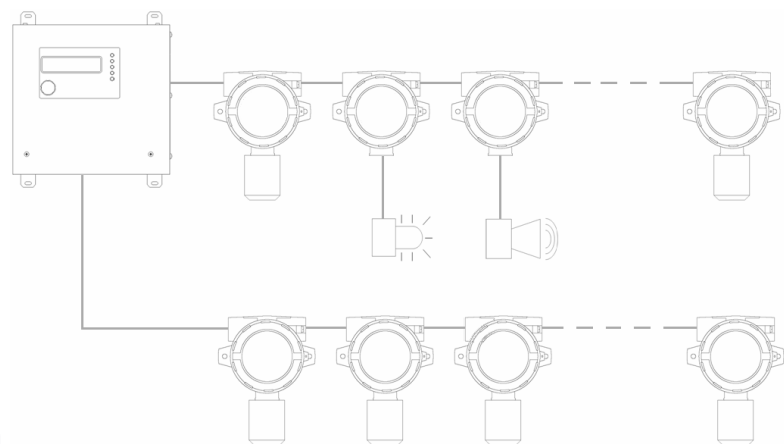

Extronics Addressable Gas Detectors

The concept of Addressable Detection is a measurement step change in Gas Detection and Extronics can provide solutions from 1-4, 1-32 and 1-255 detectors, as well as offering the operator many features that are not available with typical analogue systems.

The data communication system is based on RS485 protocol with full highway and sensor diagnostics which can be monitored and the health status reported as required by the operator. This can optimise service work by addressing any impending problems and reduce time on site.

All highway components carry a unique address which allows the operator to create a system architecture to meet with specific site requirements in terms of Zoning, alarm functionality as well as having the option of combining Addressable Highways with Analogue Loops where appropriate.

Other sensor can be added to the loops including Conventional Fire Detection devices such as smoke detectors and heat sensors.

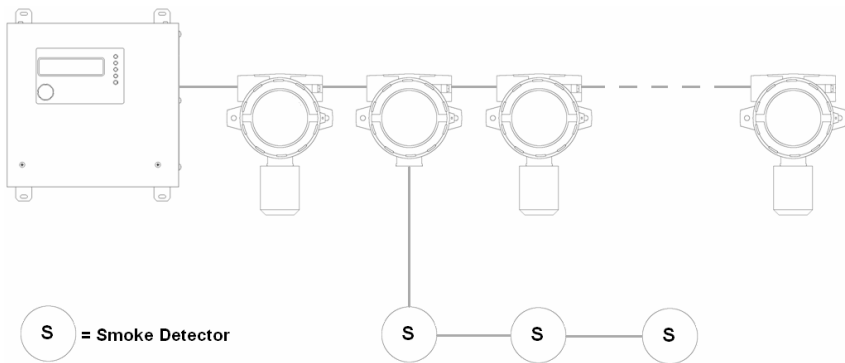

As well as adding different components to the architecture data can be accessed utilising an access node located next to the control panel with a standard PC.

Data on each of the system detectors can be downloaded to create predictive maintenance programmes allowing cell degradation to be monitored and pre-empting field failure.

The data that can be accessed during such an interrogation includes:

- Detector Date of Manufacture
- Date and Time of last calibration
- Raw Detector Data
- Results of Last Calibration

Depending upon the control panel that is used many automated features can be integrated into the functionality of the system including a simplified one man calibration routine for zero and span.

Event logging in conjunction with predictive maintenance can again radically reduce time spent on field service work keeping both hardware and labour costs to a minimum.

The application of addressable architecture can provide the operator with substantial benefits where funds may be limited and the cost of ownership is a vital factor in the purchasing decision.